



CHAIN DISK

Model 236

Installation and Operation Manual

PNEG-602

Version: 7.0

Date: 01-31-20



All information, illustrations, photos and specifications in this manual are based on the latest information available at the time of publication. The right is reserved to make changes at any time without notice.

Contents

Chapter 1 Introduction	5
Applications	5
Using the Manual	6
Background	6
Chapter 2 Safety	7
Safety Guidelines	7
Cautionary Symbols Definitions	8
Safety Cautions	9
Safety Sign-Off Sheet	11
Chapter 3 Decals	12
Chapter 4 Specifications	14
Chapter 5 Optional Equipment	15
Chapter 6 Tubing and Drop Kit	16
Laying Out the Tubing	16
Assembly of Tubing	16
Cutting Outlet Holes	17
Suspension Tube	17
Drop Kit Installation	18
Drop Feeder Installation	23
Chapter 7 Drive Unit Installation	24
Location	24
Structural Integrity of Support	24
Suspension of the Drive Unit	24
Chapter 8 Corner Installation	26
Measuring and Cutting Tube	26
Chapter 9 Fill System	28
Installation	28
Typical Fill System Installation	29
Fill Hopper Installation	30
Chapter 10 Wiring Diagrams	31
Wiring Instructions	31
Safety Regulations	31
Chain Disk with Display 24 HR Timer and Actuator Control System (APCD-500)	32
Chain Disk with Display Control System (APCD-600)	33
Single Auger Single Loop System Illustration	34
Single Auger Two (2) Loops System Illustration	35
Chapter 11 Operation Controls	36
Current Sensor	36
Limit Switch	37
Chapter 12 Testing of Controls	40
Testing Limit Switch	40

Table of Contents

Chapter 13 Chain Installation	41
Check Drive Sprocket Rotation	41
Pulling Chain through Tubing	41
Final Assembly of Corners	44
Installing Chain into Drive Unit	45
Chain Take-Up	47
Mounting Proximity Switch	47
Adjusting Sensitivity	48
Chapter 14 Maintenance	50
Chain and Disk Tension	50
Gearbox Maintenance Free	50
Bushing Replacement in Idler Wheel	50
Limit Switch Inspection	51
Chapter 15 Parts List	53
Proximity Feed Sensor for Clear PVC Tube	54
Horizontal Corner Installation and Suspension (APCD-708)	55
Vertical and Inclined Corner Installation and Suspension (APCD-703)	56
Chain Disk Drive Unit (APCD-610-150, APCD-610-160 and APCD-610-350)	58
Fill Hopper Assembly	62
PVC - Clear	63
PVC - White	63
Welded Steel Tubing	64
Drop Kits	65
Chain Disk Control Unit	66
Chapter 16 Troubleshooting	68
Chapter 17 Warranty	69

Applications

Typical Chain Disk System applications are shown as follows: (See Figure 1A.)

In poultry applications, switches may be placed in more than one hopper to assure that no hopper empties before the control unit hopper requires feed. If this is done, all switches must be wired in parallel so that any one switch can start the system. If only one hopper level control is used, it must be located at the end of the delivery system.

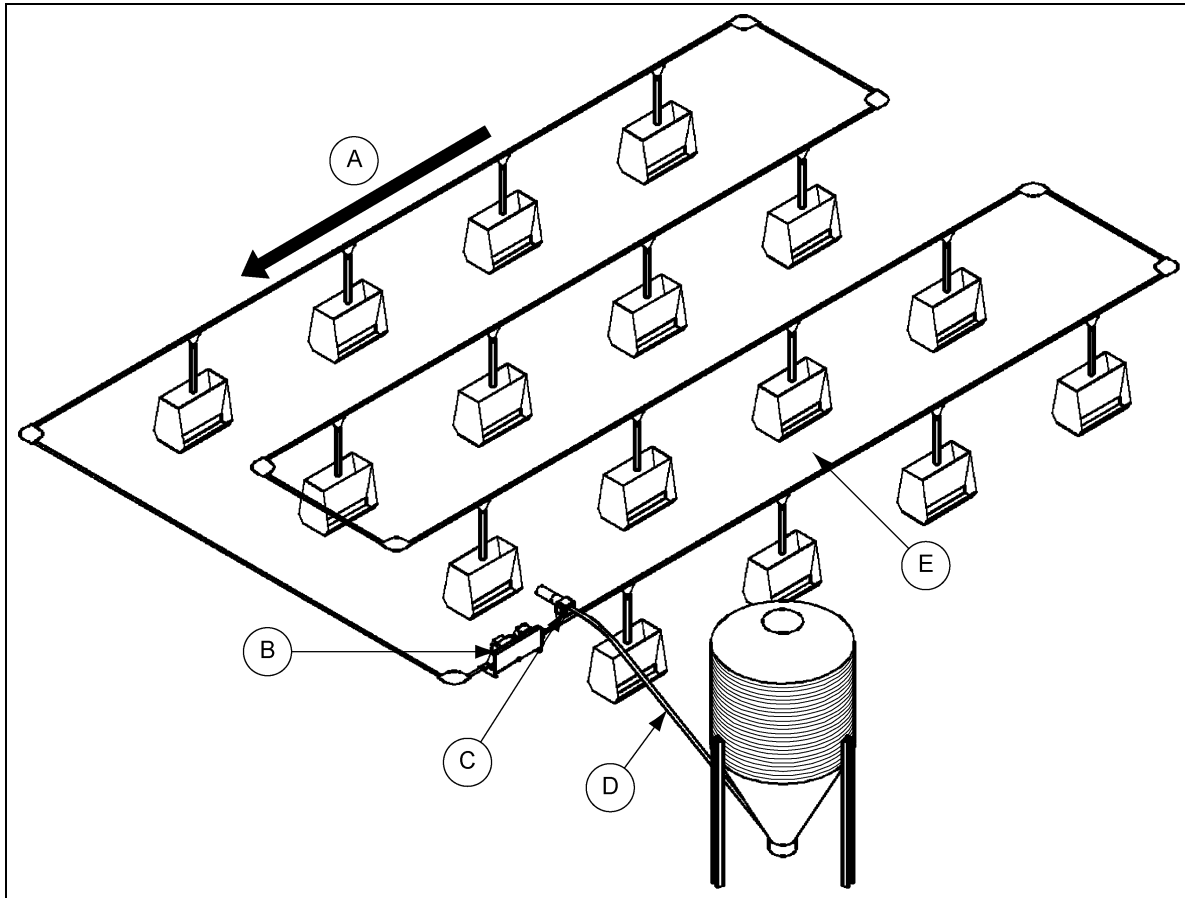

Figure 1A Typical Application

Ref #	Description
A	Direction of Travel for Chain and Disk
B	Chain Disk Drive Unit
C	Flex-Flo Control Unit
D	Flex-Flo Fill System
E	Chain Disk System

In most swine applications, the feed control is installed in the last hopper at the end of the delivery system. If a tube mounted proximity switch is used, it should be installed just beyond the last feeder.

Using the Manual

Read the entire manual prior to any work being done. This installation/owner manual is to be used as a guideline for the installation of the Chain Disk Feed System Model 236. All instructions should be construed as recommendations only, as the actual installation may vary according to local conditions. Wiring diagrams can be found later in this manual. Instructions presented in this manual should only be carried out by a trained technician. It is essential that the technician has a sound understanding of technical matters and drawings in both mechanical and electrical areas.

Background

The Chain Disk Feed System consists of a drive unit which pulls a chain with nylon disks attached to it through tubing, thus conveying feed from a storage bin to animals inside a building. The disks have approximately the same diameter as the inside of the tube, therefore being a highly efficient conveying system with total clean-out of the tube. This system can be adapted to complex configurations because of its ability to go through tight corners and at any angle including vertical. The delivery of feed can be controlled manually or automatically with the use of a control unit, sensors and drop kits.

Safety Guidelines

Safety guidelines are general-to-specific safety rules that must be followed at all times. This manual is written to help you understand safe operating procedures and problems that can be encountered by the operator and other personnel when using this equipment. Read and save these instructions.

As owner or operator, you are responsible for understanding the requirements, hazards, and precautions that exist and to inform others as required. Unqualified persons must stay out of the work area at all times.

Alterations must not be made to the equipment. Alterations can produce dangerous situations resulting in **SERIOUS INJURY** or **DEATH**.

This equipment must be installed in accordance with the current installation codes and applicable regulations, which must be carefully followed in all cases. Authorities having jurisdiction must be consulted before installations are made.

When necessary, you must consider the installation location relative to electrical, fuel and water utilities.

Personnel operating or working around equipment must read this manual. This manual must be delivered with equipment to its owner. Failure to read this manual and its safety instructions is a misuse of the equipment.

ST-0001-4

Cautionary Symbols Definitions

Cautionary symbols appear in this manual and on product decals. The symbols alert the user of potential safety hazards, prohibited activities and mandatory actions. To help you recognize this information, we use the symbols that are defined below.



This symbol indicates an imminently hazardous situation which, if not avoided, **will result in serious injury or death.**



This symbol indicates a potentially hazardous situation which, if not avoided, **can result in serious injury or death.**



This symbol indicates a potentially hazardous situation which, if not avoided, **can result in minor or moderate injury.**



This symbol is used to address practices not related to personal injury.



This symbol indicates a general hazard.



This symbol indicates a prohibited activity.



This symbol indicates a mandatory action.

ST-0005-2

Safety Cautions

Use Personal Protective Equipment

- Use appropriate personal protective equipment:

Eye Protection



Respiratory Protection



Foot Protection



Hearing Protection



Head Protection



Fall Protection



Hand Protection



- Wear clothing appropriate to the job.
- Remove all jewelry.
- Tie long hair up and back.

ST-0004-1

Follow Safety Instructions

- Carefully read all safety messages in this manual and safety signs on your machine. Keep signs in good condition. Replace missing or damaged safety signs. Be sure new equipment components and repair parts include the current safety signs. Replacement safety signs are available from the manufacturer.
- Learn how to operate the machine and how to use controls properly. Do not let anyone operate without instruction.
- If you do not understand any part of this manual or need assistance, contact your dealer.



ST-0002-1

2. Safety

Maintain Equipment and Work Area

- Understand service procedures before doing work. Keep area clean and dry.
- Never service equipment while it is operating. Keep hands, feet, and clothing away from moving parts.
- Keep your equipment in proper working condition. Replace worn or broken parts immediately.



ST-0003-1

Operate Motor Properly

- All electrical connections must be made in accordance with applicable local codes (National Electrical Code for the US, Canadian Electric Code, or EN60204 along with applicable European Directives for Europe). Make sure equipment and bins are properly grounded.
- Lock-out power before resetting motor overloads.
- Do not repetitively stop and start the drive in order to free a plugged condition. Jogging the drive in this manner can damage the equipment and drive components.



ST-0009-3

Stay Clear of Moving Parts

- Entanglement in rotating sprocket or moving chain will cause serious injury or death.
- Keep all guards and covers in place at all times.
- Lock-out power source before making adjustments, cleaning, or maintaining equipment.

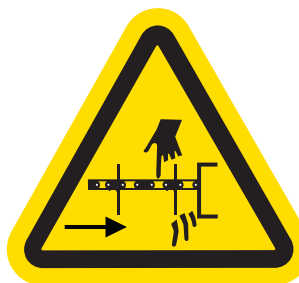

ST-0017-1

3. Decals



DC-491 is located on the front cover of the drive unit.



The GSI Group 217-226-4421

WARNING

Moving parts can crush and cut.

- Keep hands clear.
- Do not operate with guard removed.
- Disconnect and lockout power before servicing.

DC-996

DC-996 is located on the front cover of the drive unit.



DC-490 is located on the electrical box of the drive unit.

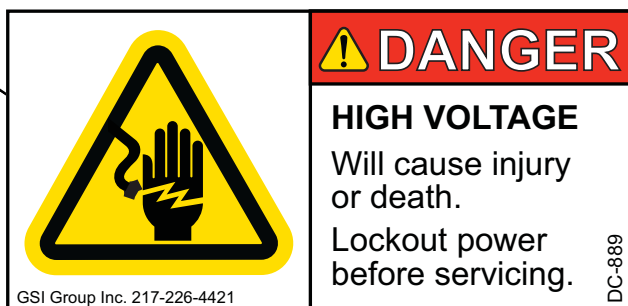

GSI Group Inc. 217-226-4421

DC-889 is located on the electrical box of the drive unit.



DC-997 is located inside the drive unit.

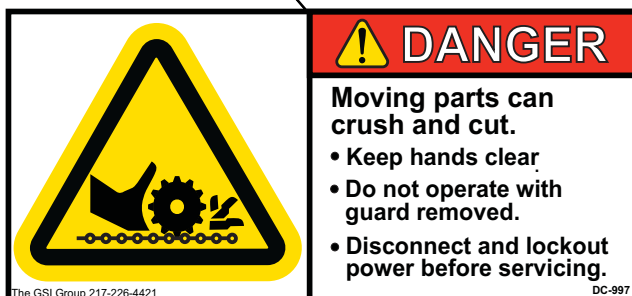

The GSI Group 217-226-4421

DC-997

4. Specifications

Capacity	The rated capacity is up to 50 lbs./min. (23 kg/min.) Capacity is based on a feed density of 40 lbs./ft. ³ (641 kg/m ³). Refer to chart on Page 28 depending on tubing material and run time.
Overall system length	The maximum effective length can be up to 2000' (610 m). Refer to chart on Page 28 . Subtract 25' (7.6 m) per corner or effective length = (Total ft. of chain) + 25' (# of corners).
Types of feed	The Model 236 Chain Disk is specifically designed to convey normal types of swine and poultry feeds. When conveying any other type of material contact the manufacturer as the warranty may be invalidated.
Tubing	There are three (3) options: <ol style="list-style-type: none"> 1. Clear and white PVC tubing having dimensions of 2.00" (51 mm) I.D. and 2.36" (60 mm) O.D. coming in 10' (3 m) lengths. Clear and white PVC couplers are used to join sections of tubing together. 2. Welded steel tube having dimensions of 2-3/8" O.D. x 2.277" I.D. Steel compression couplers are used to join sections together. Available in 10' or 21' lengths. 3. Welded steel tube having dimensions of 2-3/8" O.D. x 2.277" I.D. with precut holes on the 18" (13 holes), 19" (13 holes), 20" (12 holes), 22" (11 holes), 23" (10 holes) or 24" (10 holes) on center.
Corners	Each corner has a 9.4" (239 mm) diameter cast steel self-cleaning wheel with non-greasable ball bearings encased in a clear polycarbonate housing with a removable cover.
Chain	The flexible chain is heat treated with a 3000 lbs. (13.3 kN) breaking strength. Nylon disks having 1.7" (43 mm) O.D. are molded on every other chain link. The chain is connected together using a special open link connector. The disks are symmetrical, making the chain non-directional.
Drive unit	The drive unit, having dimensions of 51.6" (1.3 m) length, 17.6" (0.4 m) height and 20.3" (0.5 m) width, is an enclosed stainless steel housing with a spring loaded aluminum idler tensioning wheel and drive sprocket inside. The drive sprocket is directly coupled to the output shaft of an aluminum housed speed reducer, which in turn is driven by an electric motor.
Electric motor	There are three (3) special built 1.5 HP motors to choose from: 208V-230V, 1 PH, 60 Hz; 230V, 1 PH, 50 Hz; 208V-230V/460V, 3 PH, 50/60 Hz.
Control unit	A 230V, 1 PH unit is available. With an additional 3 PH contactor, it can be used to control a 3 PH drive unit. The APCD-500 control unit has a built in 24 hours time clock, maximum run timer and drop feed control. The APCD-600 has a built in maximum run timer and is used for continuous feeding. The APCD-500-S is used in conjunction with the APCD-500, when configuring feed systems with multiple Chain Disk drive units. A single APCD-500 can control up to seven (7) APCD-500-S control units.

Part #	Description
	Model 300 Flex-Flo fill system or comparable equivalent having a maximum of 50 lbs./min. (23 kg/min.) rated capacity.
APCD-620	Chain Disk fill hopper which connects to Flex-Flo control unit.
APCD-109	Manual kwik-attach drop kit (single).
APCD-110	Manual kwik-attach drop kit (box of 10).
APCD-119	Pneumatic kwik-attach drop kit assembly.
APCD-710	Drop kit for Chain Disk with pull cord (single).
APCD-710-10	Drop kit for Chain Disk with pull cord (box of 10).
AP-1260	ACCU-DROP feeders fitting tube with 2.36" (60 mm) outside diameter.
AP-2259	Farrowing drop feeder - Model 236 (8.5 lbs. capacity).
AP-2263	Farrowing drop feeder - Model 236 (12 lbs. capacity).
APCD-294	Tube mounted proximity switch.
FLX- 4256	Proximity switch, 20V DC to 240V AC, N.O. (used with APCD-294).
AP-2385	ECONO-DROP feeder fitting tube with 2.36" O.D. PVC tube.
AP-3800	ULTRA-DROP feeders for gestation with 2.36" O.D. PVC tube or welded steel tube.
AP-3800A	ULTRA-DROP feeders for farrowing with 2.36" O.D. PVC tube or welded steel tube.

6. Tubing and Drop Kit

Refer to [Page 24](#) for tubing option.

Laying Out the Tubing

Laying out the tubing is one of the most important steps in the installation of the Chain Disk System. Place the tubes in approximately the position where they will be installed (either on the ground or on top of the penning for the time being). If white PVC or welded steel tubing is used it would be helpful to place sections of clear PVC tubing at various places throughout the system for easy viewing of the feed, especially before and after the fill hopper and where the proximity switch is located. **Things to consider: the system must be closed looped, sections of tubing can go in any direction and the change in direction of the tubing must be 90°.** For now overlap the tubes where there is to be a corner and leave the cutting of the tubes to fit various components until these components are installed which will be later on. Establish where the outlet drops are to be. **Make sure that the ends of these tubes do not meet where there is to be a drop kit or drop feeder.** If they do, one end of the tube must be cut off enough so the coupler will miss the drop kit.

Assembly of Tubing

Once the tubing has been properly laid out the tubes need to be connected together in long sections. Assemble long sections of white or clear PVC tubing using glued couplers. Assemble long sections of welded steel tubing using steel compression couplers.

NOTE: *Maximum length of each section should not exceed the length of fish tape which will be used later on to install chain.*

NOTE: *For extremely long systems of PVC tubing, we recommend gluing only one side of the coupler leaving an 1/8" (3 mm) gap between ends of tubing to allow for tubing expansion.*

Chain Disk Systems use specially formulated PVC tubing. For strong tube connections, apply the PVC solvent cement as the instructions below suggest:

1. Square tube ends and remove all burrs and dirt.
2. Check to make sure all connections are smooth.
3. When the temperature is below 40°F or above 85°F, consult PVC solvent cement container.
4. Apply a coat of cement to both parts being connected.
5. Assemble parts quickly. CEMENT MUST BE FLUID - if not fluid, re-coat both parts.
6. While still fluid, rotate tubes 1/4 turn back and forth to spread out cement properly.
7. Hold parts together for 30 seconds - wipe off excess cement with cloth. Completed joints should not be disturbed until they have cured enough to withstand handling. Keep container closed when not in use.

Cutting Outlet Holes

With the sections of tubing still layed out and the placement of the drop kits already established, the next step is to mark on the top of the tube where each drop kit is to be. The reason for marking the tube in advance is to make sure the holes stay aligned even if the tubes rotate as the holes are being cut. Once the tubes are marked, cut the holes for the outlet drops as shown in [Figure 6A](#) and [Figure 6B](#). Use a saber saw or hack saw to cut extended outlet holes. Use a hole saw or uni-bit (step drill) to cut outlet holes. Be sure to remove any burrs after cutting so the drop kit can perform properly.

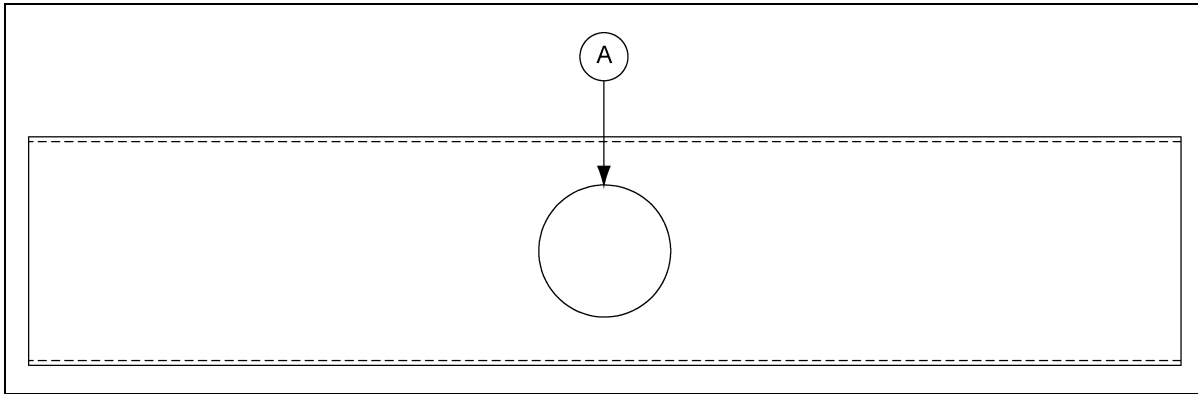

Figure 6A Outlet Hole for Partial Drop-Out in Welded Steel and PVC Tubing
(Used with Drop Kits and Drop Feeders)

Ref #	Description
A	Ø 1-3/8" (35 mm)

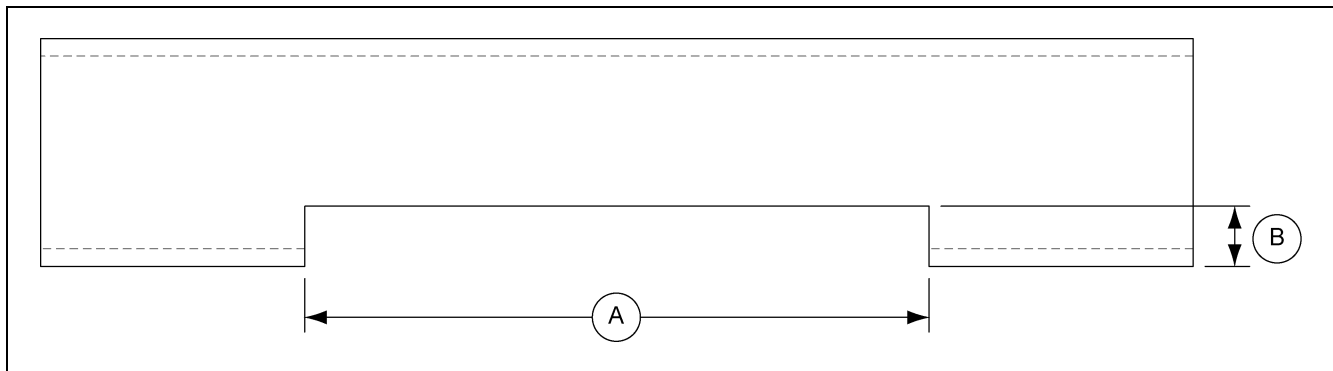

Figure 6B Extended Outlet Hole with Total Drop-Out (Only used with Kwik-Attach Drop Kit)

Ref #	Description
A	6-1/2" (165 mm)
B	5/8" (16 mm)

Suspension Tube

IMPORTANT: Suspend the sections of PVC tubing every 4' and welded steel tubing every 8' from the ceiling. To minimize drag and wear keep the sections of tubing as straight as possible. Failure to do this will void the warranty.

Drop Kit Installation

Kwik-Attach

1. Snap the slide around the tube over the outlet hole. *(See Figure 6C.)*
2. Fasten the housing to the tube using two (2) hose clamps. Make sure the outlet hole is in the middle of the housing.
3. Slide can be rotated from side to side to open and close the drop kit.

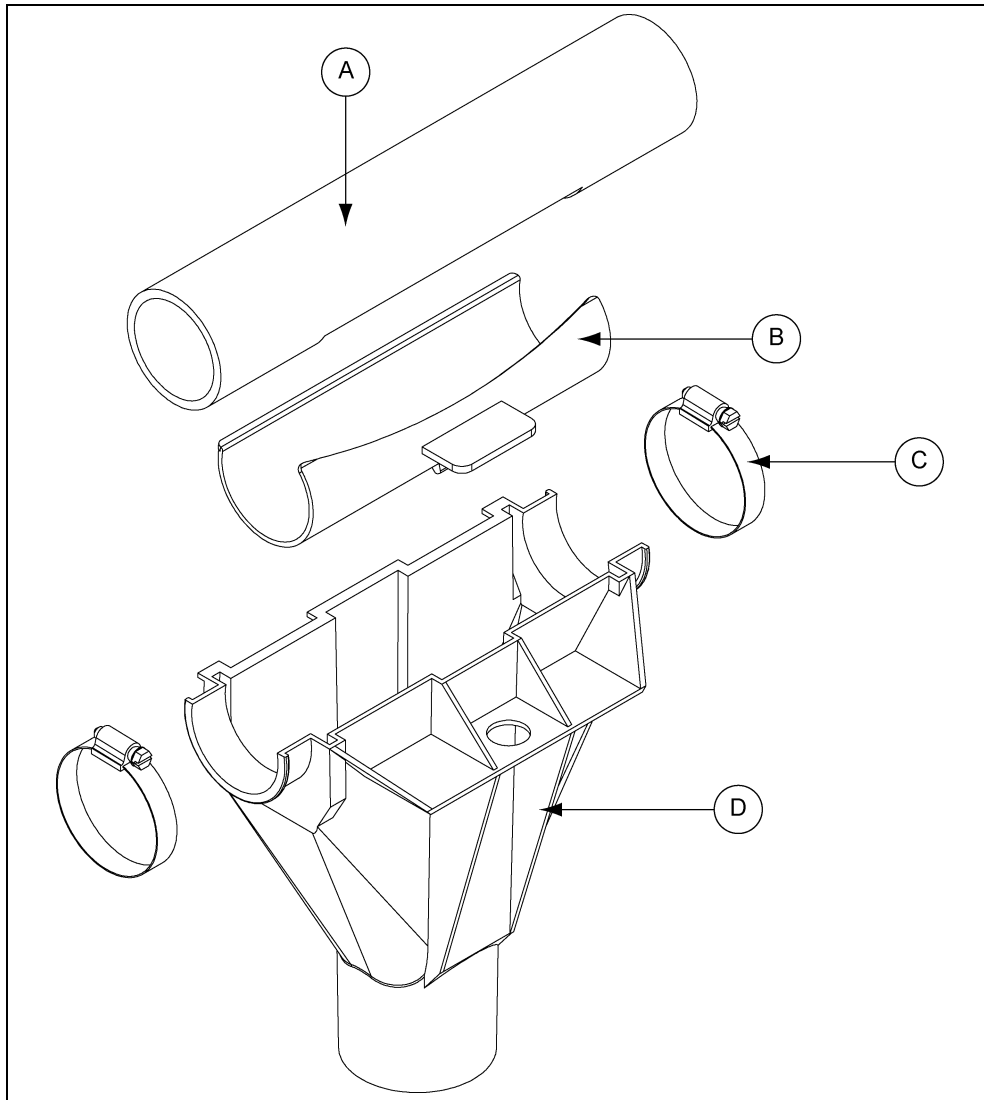

Figure 6C Kwik-Attach Drop Kit Installation for PVC and Welded Steel Tubing (APCD-109)

Ref #	Description
A	PVC or Welded Steel Tubing
B	Slide
C	Hose Clamp (2)
D	Housing

Pull Cord Style Drop Kit Installation

1. Put a knot in the center of the cord.
2. Wrap a rotary slide (A) around the auger tube and align it with an outlet hole. (See Figure 6D.)

IMPORTANT: Position the rotary slides (A) with the cutout (B) facing the same direction for all drops to ensure uniform operation.

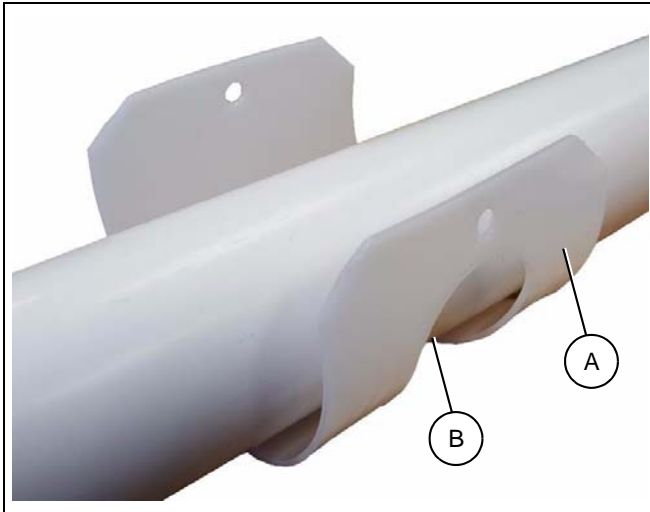

Figure 6D

Ref #	Description
A	Rotary Slide
B	Cutout

3. Thread one end of the cord through both holes in the top of the rotary slide (A). (See Figure 6E.)

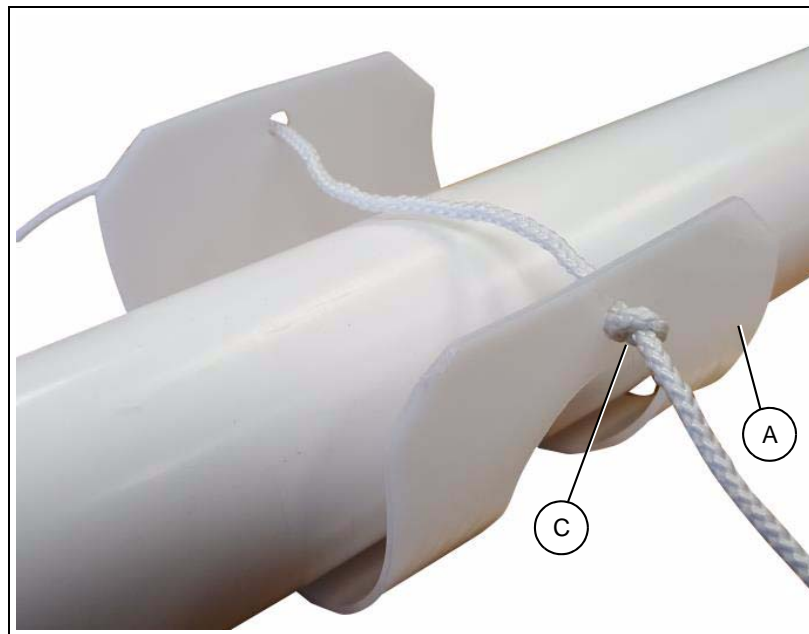

Figure 6E

Ref #	Description
A	Rotary Slide
C	Knot

6. Tubing and Drop Kit

4. Loop the cord over and back through both holes again. (See Figure 6F.)

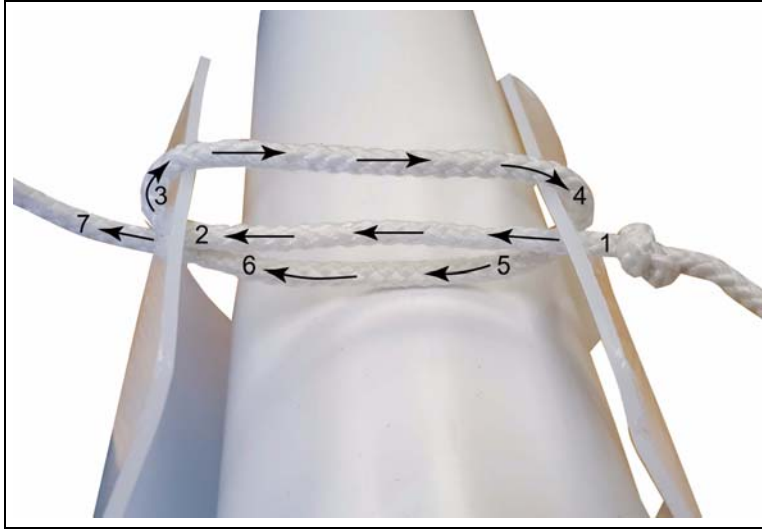

Figure 6F

5. Pull the cord tight until the first knot is firmly seated against the rotary slide (A) and the ends of the rotary slide touch each other evenly.
6. Tie a second knot (D) on the opposite side, making sure it is seated firmly against the rotary slide and there is no gap in the rotary slide (E). (See Figure 6G.)

NOTE: It is important that the ends of the rotary slide (E) touch evenly and the cord is flat against the seam so it does not catch on the drop halves. If needed, have someone hold the rotary slide (E) closed while tying the knot.

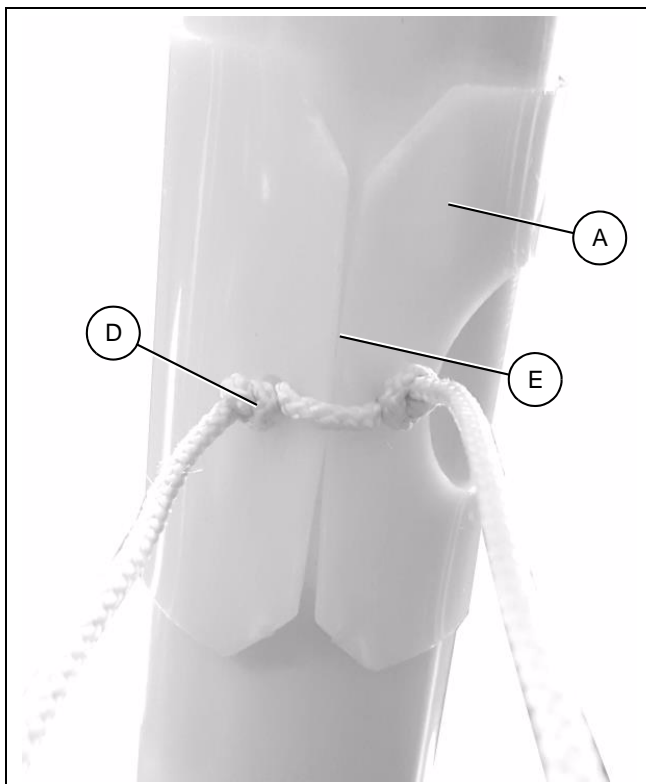

Figure 6G

Ref #	Description
A	Rotary Slide
D	Second Knot
E	No Gap in Rotary Slide

7. Position the drop halves over the pipe and thread the cord through the guide holes (F).
(See Figure 6H.)

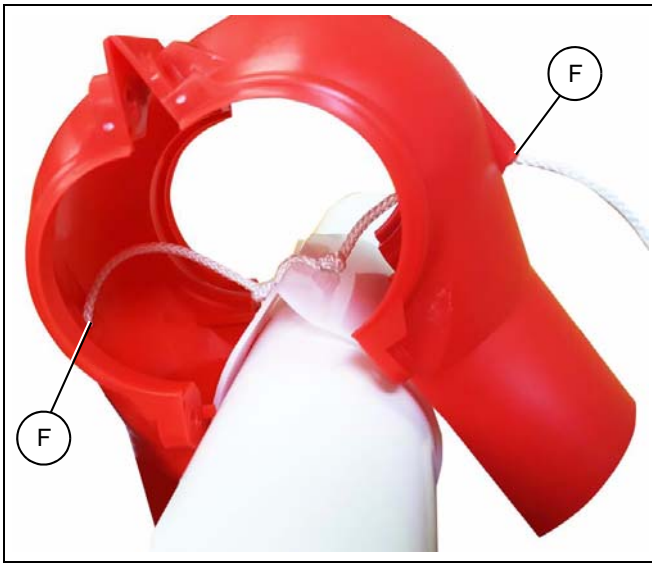

Figure 6H

Ref #	Description
F	Cord through guide holes

8. Insert a hex nut (G) into each of the four hexagon shaped sockets on the drop halves and fasten the halves together using screws. (See Figure 6I.)



Figure 6I

Ref #	Description
G	Hex Nut in Socket

6. Tubing and Drop Kit

- Pull on the cord until the rotary slide opening is centered over the hole in the auger tube.

NOTE: Check by looking up through the drop opening.

- Mark the cord on the opposite side where it enters the guide hole and tie a knot (C). Also, install the red indicator ball (I) at the end of this cord and tie a knot (C). (See Figure 6J.)

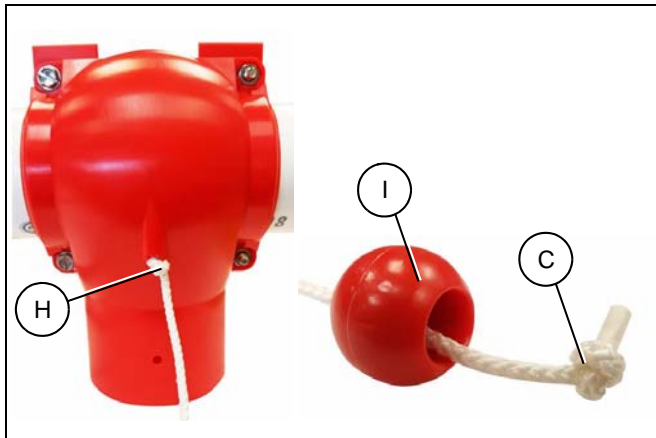

Figure 6J

Ref #	Description
C	Knot
H	Stop Knot
I	Red Ball

- Pull on the red indicator ball (I) until the rotary slide is fully covering the opening in the auger tube.

NOTE: Check by looking up through the drop opening.

- Mark the cord on the opposite side where it enters the guide hole and tie a knot. Also, install the green indicator ball at the end of this cord and tie a knot.
- Test that the outlet drop closes when pulling on the red ball and opens after pulling on the green ball. (See Figures 6K and 6L.)



Figure 6K Closed Position



Figure 6L Open Position

- Dab PVC cement around the auger tube on both sides of the outlet drop to prevent it from shifting along the tube.
- Use the supplied screws to attach an optional drop tube to the outlet drop kit.

Drop Feeder Installation

Refer to the Drop Feeder Installation and Operational Manual to install the drop feeders.

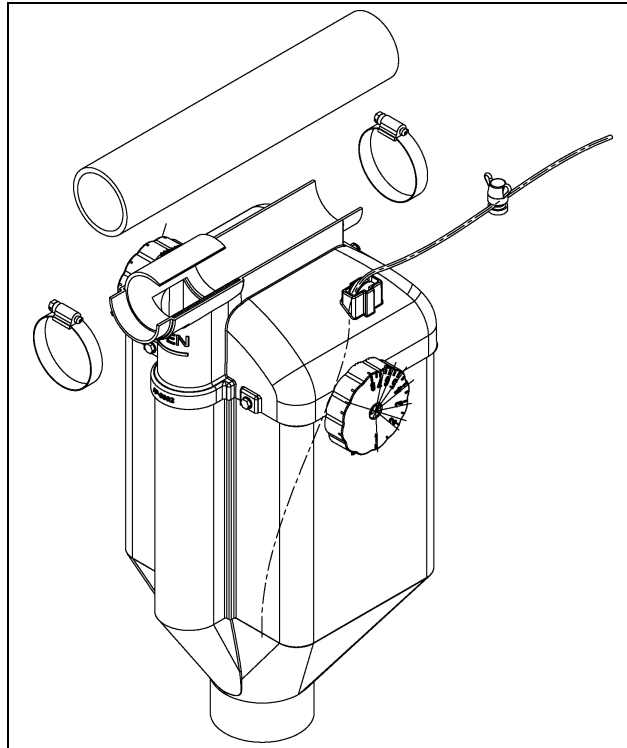

Figure 6M Ultra-Drop Feeder on Welded Steel and PVC Tubing (AP-3800)

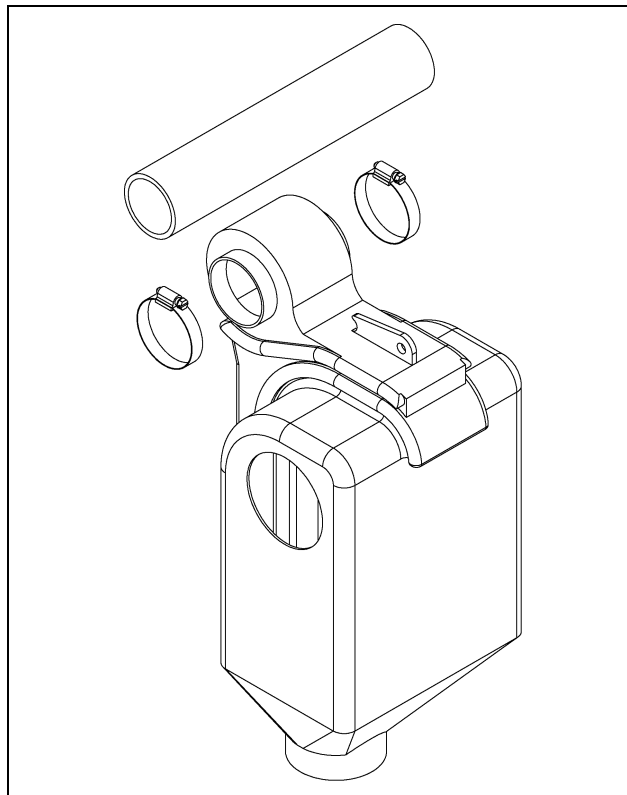

Figure 6N Econo-Drop Feeder on PVC and Welded Steel Tubing (AP-2385)

7. Drive Unit Installation

Location

The Chain Disk Model 236 drive unit is designed in such a way that if feed enters the drive unit, it is able to carry it back out again. Because of this, the drive unit can be placed anywhere in the system given consideration to accessibility and potential traffic around it. The drive unit can also be bolted to the floor (bolts not provided) or suspended, keeping in mind that the position of it in relationship to the rest of the system will affect the number of corners needed.

However the best position to locate the drive unit is between the last feeder and the fill hopper. This ensures that only a minimum amount of feed flows through the drive unit.

Structural Integrity of Support

The entire drive unit weighs approximately 170 lbs. If the drive unit is suspended, the structural member(s) from which it is suspended must be able to support it. ***Extreme caution should be used to avoid structural damage and bodily injury.*** To evaluate structural integrity of the support consult a qualified structural engineer.

Suspension of the Drive Unit

Although the drive unit can be bolted to the floor, the most common installation is to suspend the drive unit. (See [Figure 7A on Page 25.](#)) The suspension unit is included with the drive unit.

1. Screw lag screw eye bolts into structural members approximately 48" (1.2 m) apart from one another to provide a stable suspension.
2. Measure and cut chain into four (4) equal length sections leaving each plenty long for adjustment later.
3. Hook chain over lag screw eye bolts in ceiling.
4. Suspend drive unit by hooking other end of the chain over leveling eye bolts on the suspension unit.
5. Level drive unit by re-hooking chain or by screwing leveling eye bolts in or out.

Tubing Connections

6. Cut the PVC or welded steel tubing so that it butts up to the stainless steel tubing on both the inlet and outlet side of the drive unit.

For the PVC Tubing

7. Install the PVC couplers to the drive unit and secure with saddle clamps.

For the Welded Steel Tubing

8. Install the steel compression couplers to the drive unit and tighten securely.

Suspension of the Drive Unit (Continued)

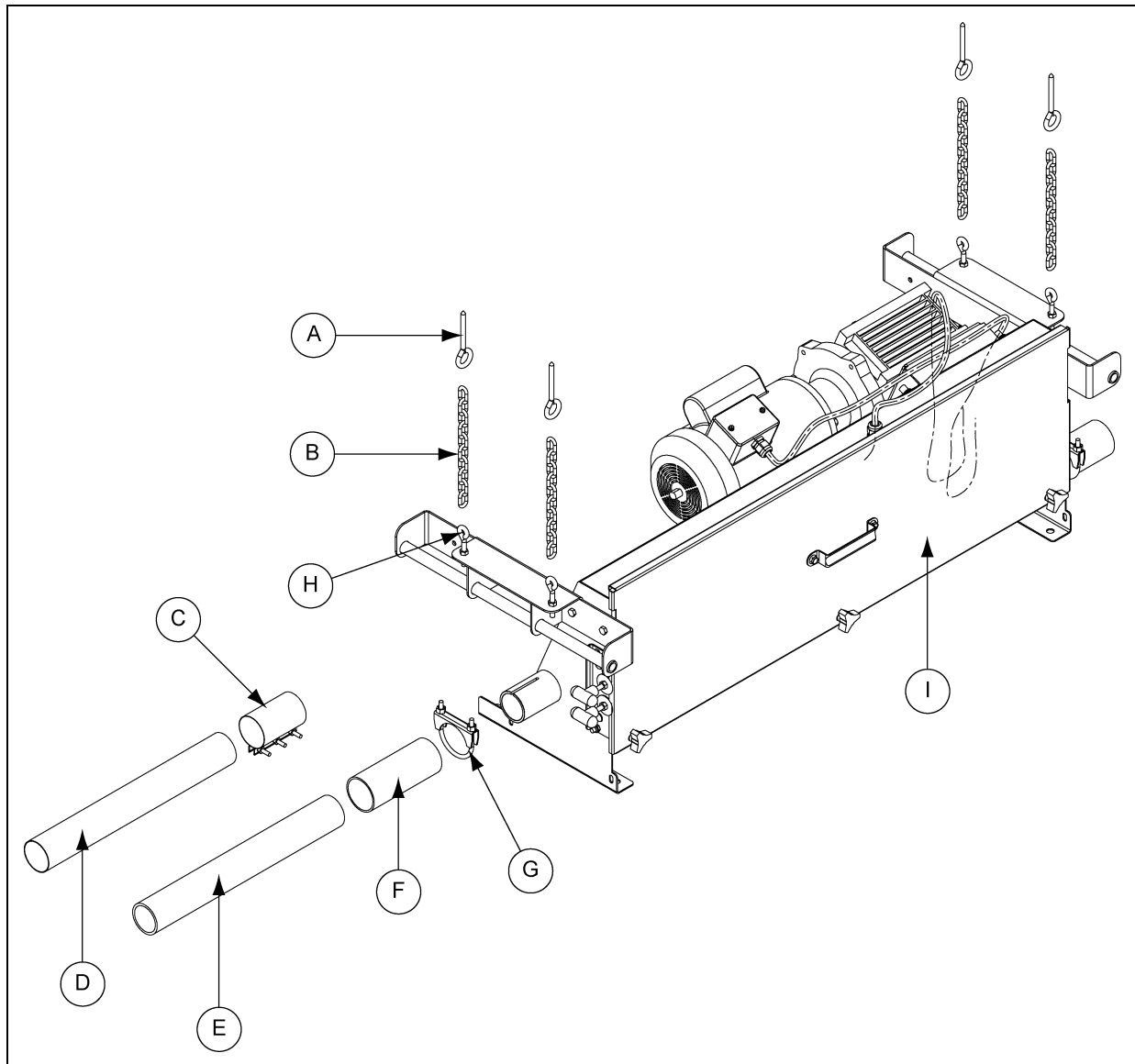

Figure 7A Drive Unit Installation and Suspension

Ref #	Description
A	Lag Screw Eye Bolt (4)
B	Chain (4)
C	Steel Compression Coupler
D	Welded Steel Tube
E	PVC Tube
F	PVC Coupler
G	Saddle Clamp
H	Leveling Eye Bolts (4)
I	Drive Unit

8. Corner Installation

Measuring and Cutting Tube

Ends for Corners

1. Remove the top from the corner and hold the rest of it in place to mark the tubes for cutting.
(See Figure 8A.)
2. Cut the tubes so they extend into the corner up to the shoulder provided in the molding.

Initial Assembly of Corners

1. Bolt the bottom of the corner to the tubes using the add on clamps (these parts need to be snapped off of the top), 5/16" x 1-1/4" bolts, 5/16" nuts.
2. Replace the 1/2" neoprene backed flat washer and 1/2" lock nut on the pivot shaft to retain the idler wheel from being pulled off during chain and disk installation. The top of the corner can remain off until after the chain and disks are installed. Corner must be suspended using the two (2) wire suspension angles provided to avoid tubing wear. Use one wire suspension angle on each side of the corner. (See Figure 8A below and Figure 8B on Page 27.) Place wire suspension angles over the add on clamps so that corners will be supported before tops are installed.

IMPORTANT: Two (2) corner wire suspension angles must be used to support each corner. Failure to properly suspend corners will void warranty.

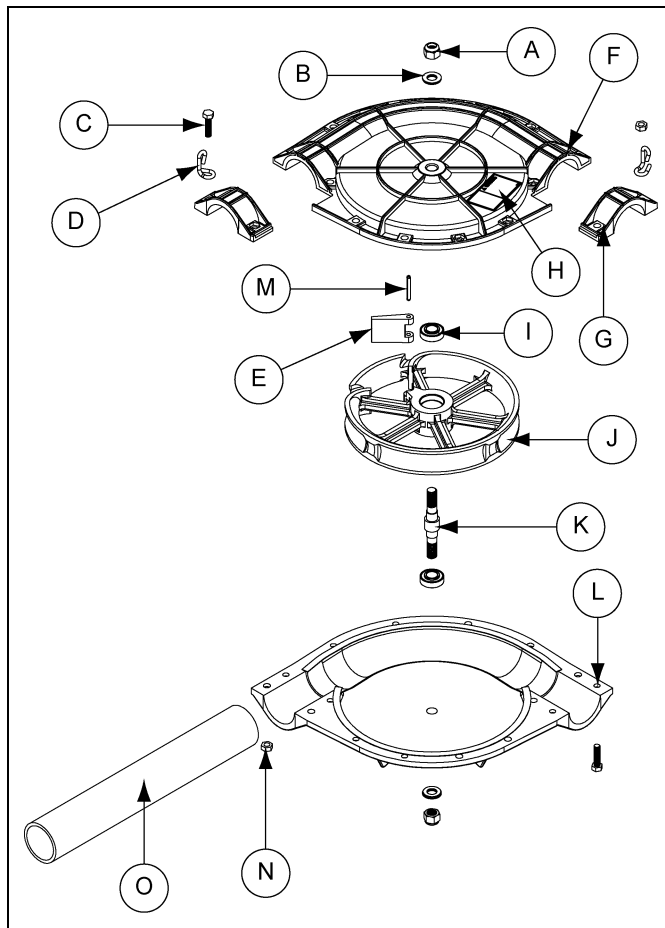

Ref #	Description
A	1/2" Lock Nut (2)
B	1/2" Neoprene Backed Flat Washer (2)
C	5/16"-18 x 1-1/4" Hex Bolt (16)
D	Wire Suspension Angle (2)
E	Wiper
F	Corner Top
G	Add on Clamp
H	Decal
I	Bearing (2)
J	Idler Wheel
K	Shaft
L	Corner Bottom
M	Spring Pin 3/16" x 1-1/2"
N	5/16"-18 Hex Nut (16)
O	PVC or Welded Steel Tubing

Figure 8A Horizontal Corner Installation and Suspension

Measuring and Cutting Tube (Continued)

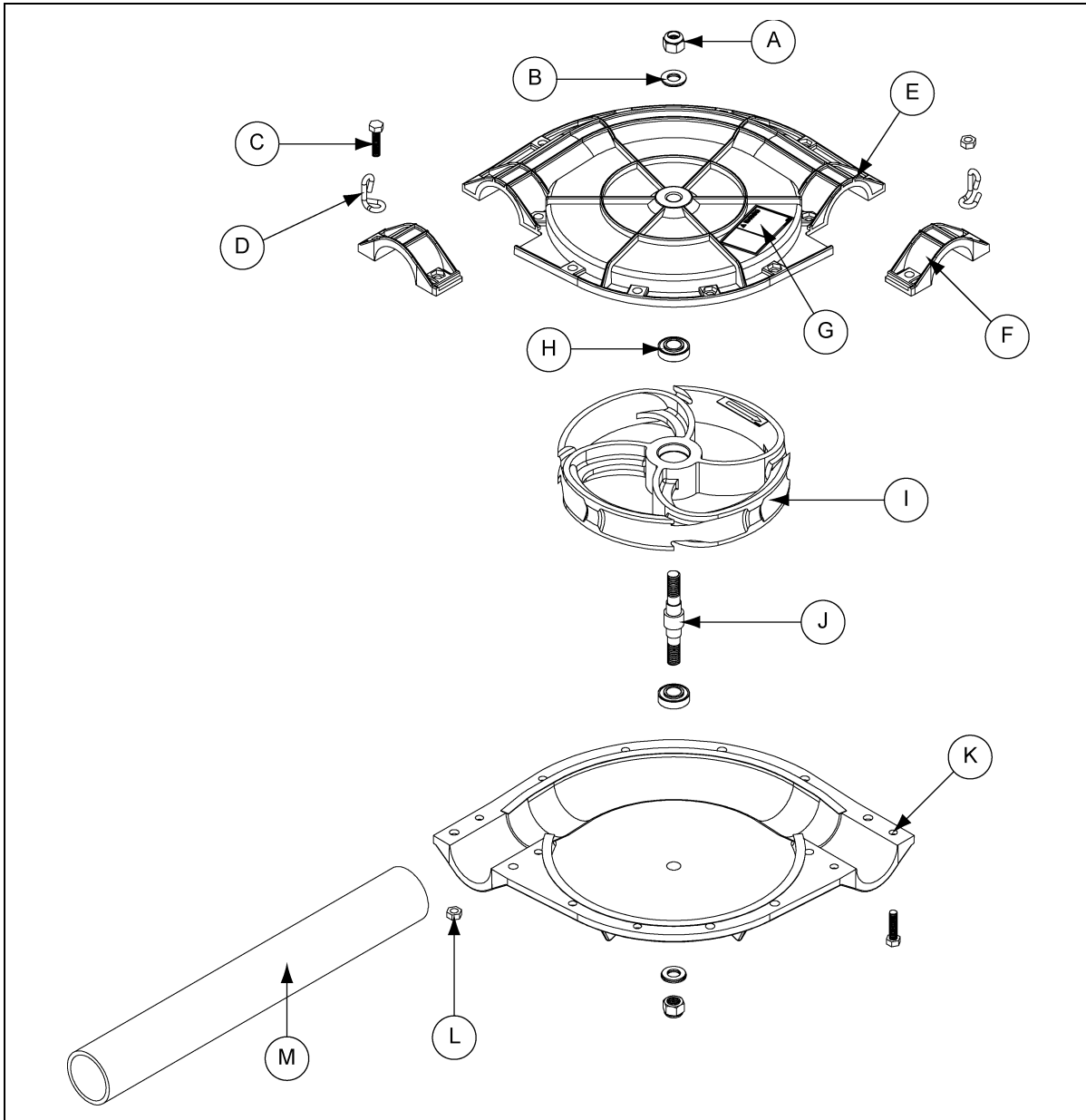

Figure 8B Vertical and Inclined Corner Installation and Suspension

Ref #	Description
A	1/2" Lock Nut (2)
B	1/2" Neoprene Backed Flat Washer (2)
C	5/16"-18 x 1-1/4" Hex Bolt (16)
D	Wire Suspension Angle (2)
E	Corner Top
F	Add on Clamp
G	Decal

Ref #	Description
H	Bearing (2)
I	Idler Wheel
J	Shaft
K	Corner Bottom
L	5/16"-18 Hex Nut (16)
M	PVC or Welded Steel Tubing

9. Fill System

Installation

Figure 9A on Page 29 shows a typical Chain Disk installation including a Flex-Flo System. A Flex-Flo System must be used to transport feed from the bulk feed tank to the Chain Disk System inside the building. In colder climates the Chain Disk System can lock up when used outside due to freezing whereas the auger in the Flex-Flo System can break loose frozen feed due to its outside rotational motion and winding up tendency.

IMPORTANT: The correct gearbox must be used on the Model 300 Flex-Flo System to prevent overfilling of the Chain Disk System.

Table below shows the maximum fill system rate for different effective lengths of a Chain Disk System and the corresponding Flex-Flo gearbox RPM to deliver that rate. The effective length is determined by adding the length of chain plus 25' (0.7 m) per corner. Refer to Model 300 Flex-Flo Installation and Operation Manual for proper installation of the Flex-Flo System. The Flex-Flo System can run parallel or perpendicular to the Chain Disk System.

Chain Disk System Design Criteria

Chain Disk Tube	Recommended Applications	Chain Disk System must not exceed any of these four (4) design criteria.				Flex-Flo Fill System	Effective Length	Effective Capacity *** (lbs./min.)
		Maximum Corners	Maximum Chain	Maximum Effective Length *	Maximum Daily Run Time **			
2.36" O.D. PVC Tube	Farrowing/Lactation Nursery	24 Corners	1150'	1750 Effective Feet	100 Minutes per Day	Model 300 at 250 RPM (35 pounds per minutes)	Up to 1000	35
							1000-1250	30
							1250-1500	25
							1500-1750	20
2.375" O.D. Welded Steel Tube	Breeding and Gestation with Electronic Sow Feeding (ESF)	24 Corners	1900'	2000 Effective Feet	240 Minutes per Day	Model 300 at 250 RPM (35 pounds per minutes)	up to 1500	35
							1500-1750	30
							1750-2000	25
							Finishing	24 Corners
	1000-1250	45						
	1250-1500	40						
	1500-1750	35						
							1750-2000	30

* **Effective length** of a Chain Disk System = Total feet of Chain Disk chain + (number of Chain Disk corners x 25).
Example: Seven hundred feet of Chain Disk tubing + (Sixteen Chain Disk corners x twenty five) = 1100 Effective ft.

** **Daily run time** of a Chain Disk System = Maximum daily feed requirement divided by "Effective Capacity".
Example: Eight hundred gestating sows x five pounds per sow per day (4000 lbs.)/20 pounds per minute "Effective Capacity" = 200 minutes.

*** **Effective capacity** of a Chain Disk System is the estimated actual fill rate of the system when adjusted for the cycling of the Flex-Flo fill system by the Chain Disk controller's current sensor to prevent system overload.

Typical Fill System Installation

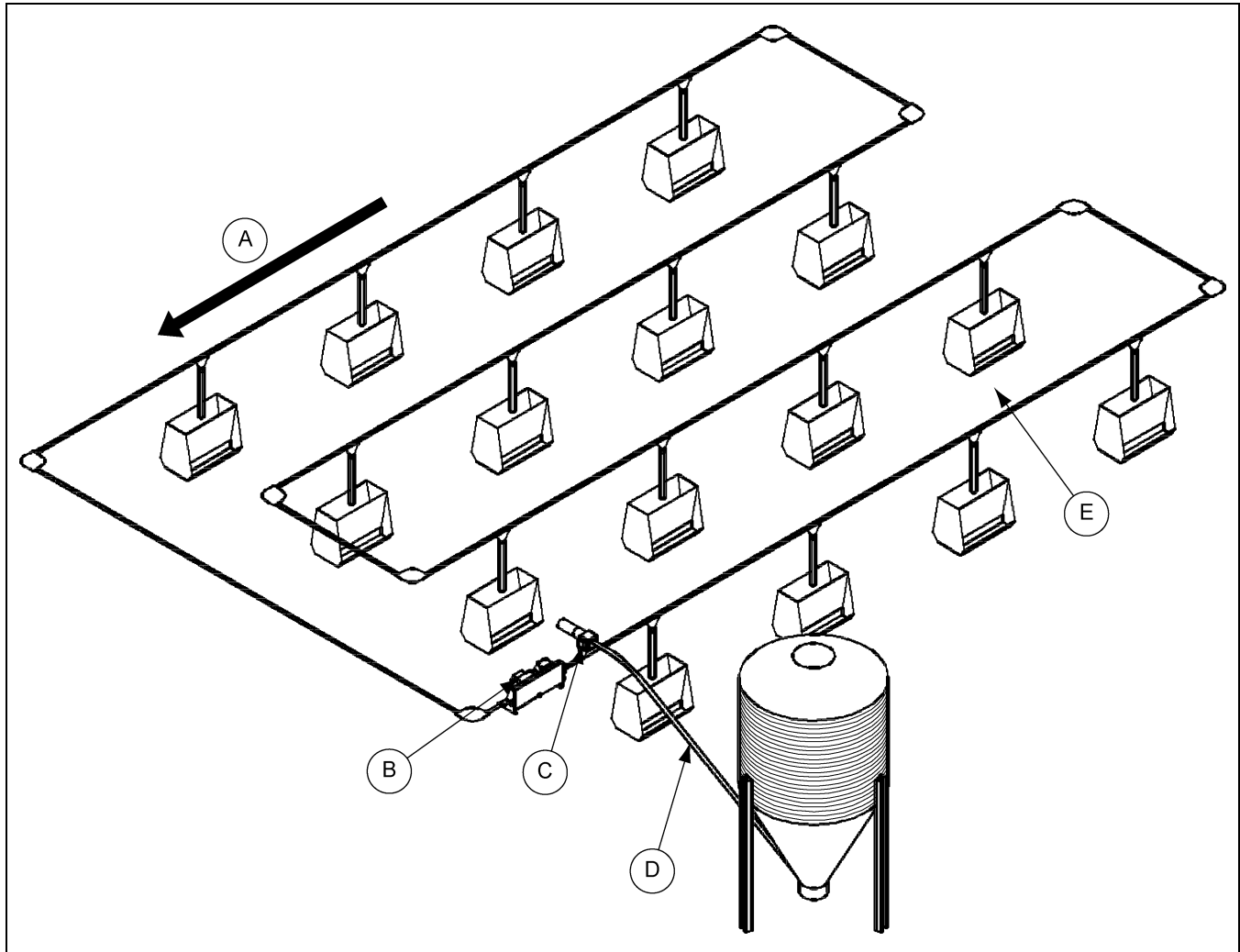

Figure 9A Typical Fill System Installation

Ref #	Description
A	Direction of Travel for Chain and Disk
B	Chain Disk Drive Unit
C	Flex-Flo Control Unit
D	Flex-Flo Fill System
E	Chain Disk System

9. Fill System

Fill Hopper Installation

1. Attach fill hopper to the Flex-Flo control unit using #10 x 1" self-drilling screws provided with Flex-Flo control. (See [Figure 9B.](#))
2. Adjust the suspension height of the control unit until fill hopper is in line with tubing.
3. Refer to [Page 24](#) for tubing connections.

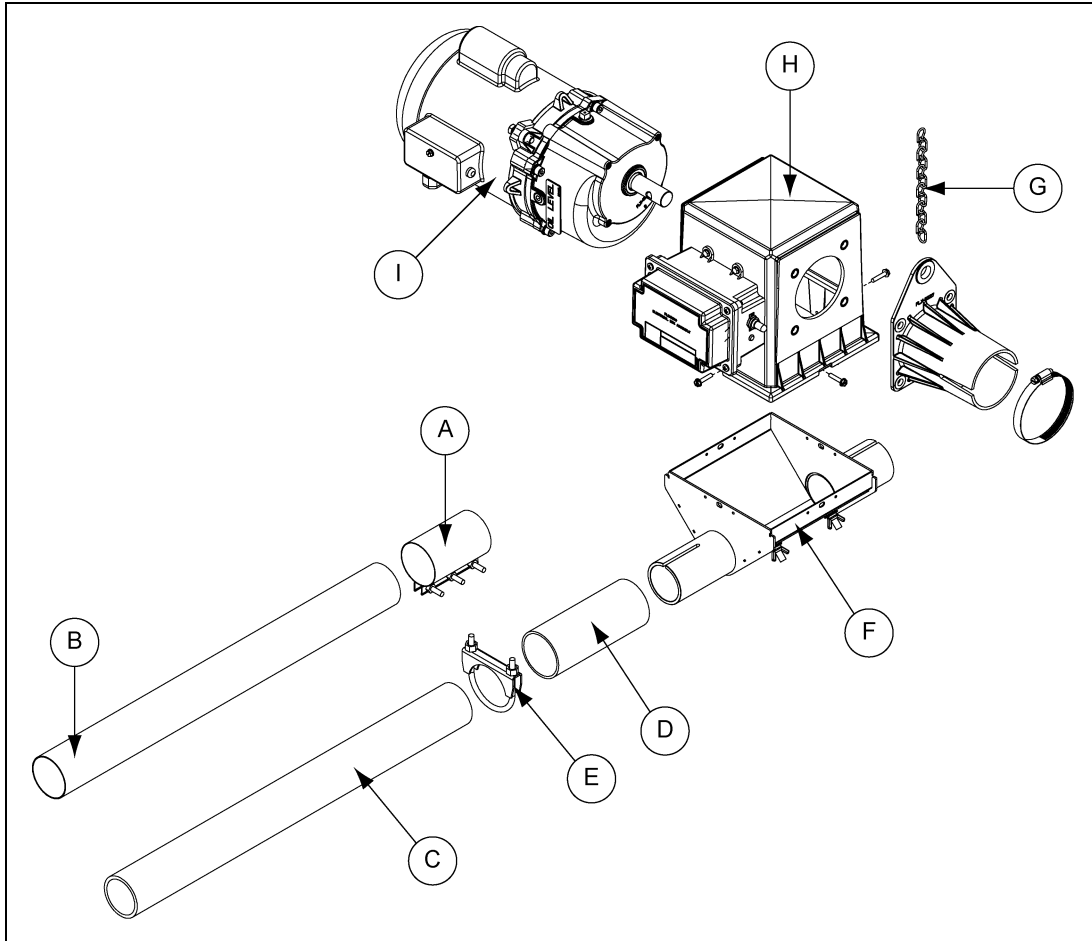

Figure 9B *Fill Hopper Installation*

Ref #	Description
A	Steel Compression Coupler
B	Welded Steel Tube
C	PVC Tube
D	PVC Coupler
E	Saddle Clamp
F	Chain Disk Fill Hopper
G	Suspension Chain
H	Flex-Flo Control Unit
I	Flex-Flo Power Unit

Wiring Instructions



1. **Disconnect all electrical power before inspecting or servicing equipment unless maintenance instructions specifically state otherwise.**
2. **Keep hands and tools away from exposed Chain Disks.**
3. **Do not operate equipment without covers and guards properly positioned. Failure to do so may cause personal injury or damage to the equipment.**

Safety Regulations

1. All wiring should be done by a qualified electrician in accordance with local and national electrical codes.
2. Ground all electrical equipment for safety.
3. Use proper size wire according to the national electrical codes to wire all systems. (See Figure 10A.)

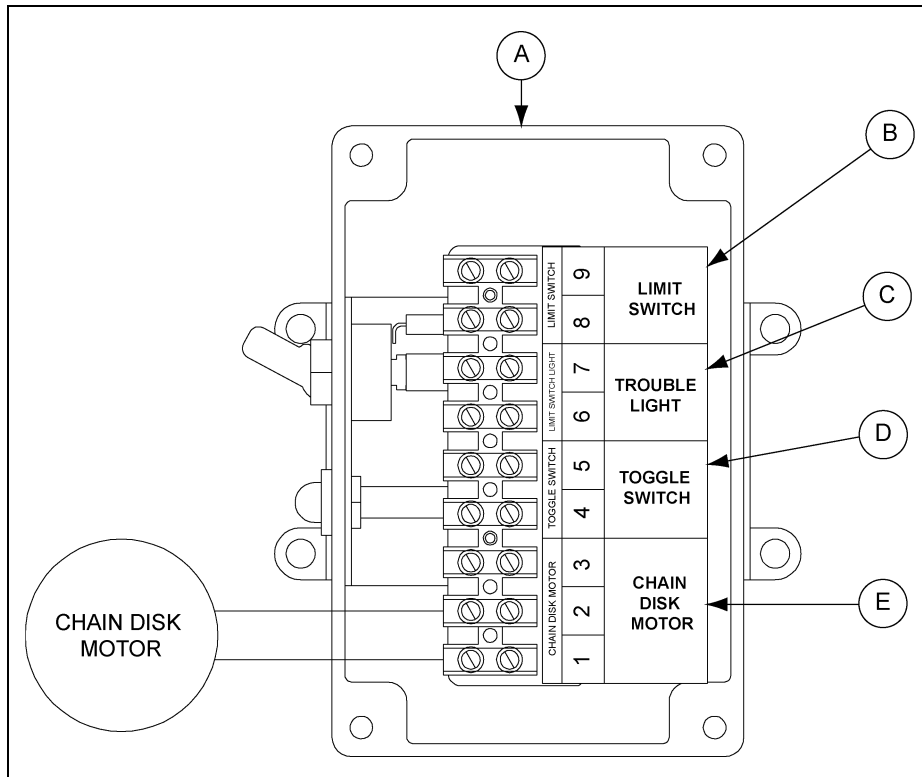

Figure 10A Chain Disk Junction Box

Ref #	Description
A	Chain Disk Drive Unit Electrical Junction Box
B	To Safety Switch Terminals
C	To Trouble Light Terminals
D	To Toggle Switch Terminals
E	To Contactor Terminals

10. Wiring Diagrams

Chain Disk with Display 24 HR Timer and Actuator Control System (APCD-500)

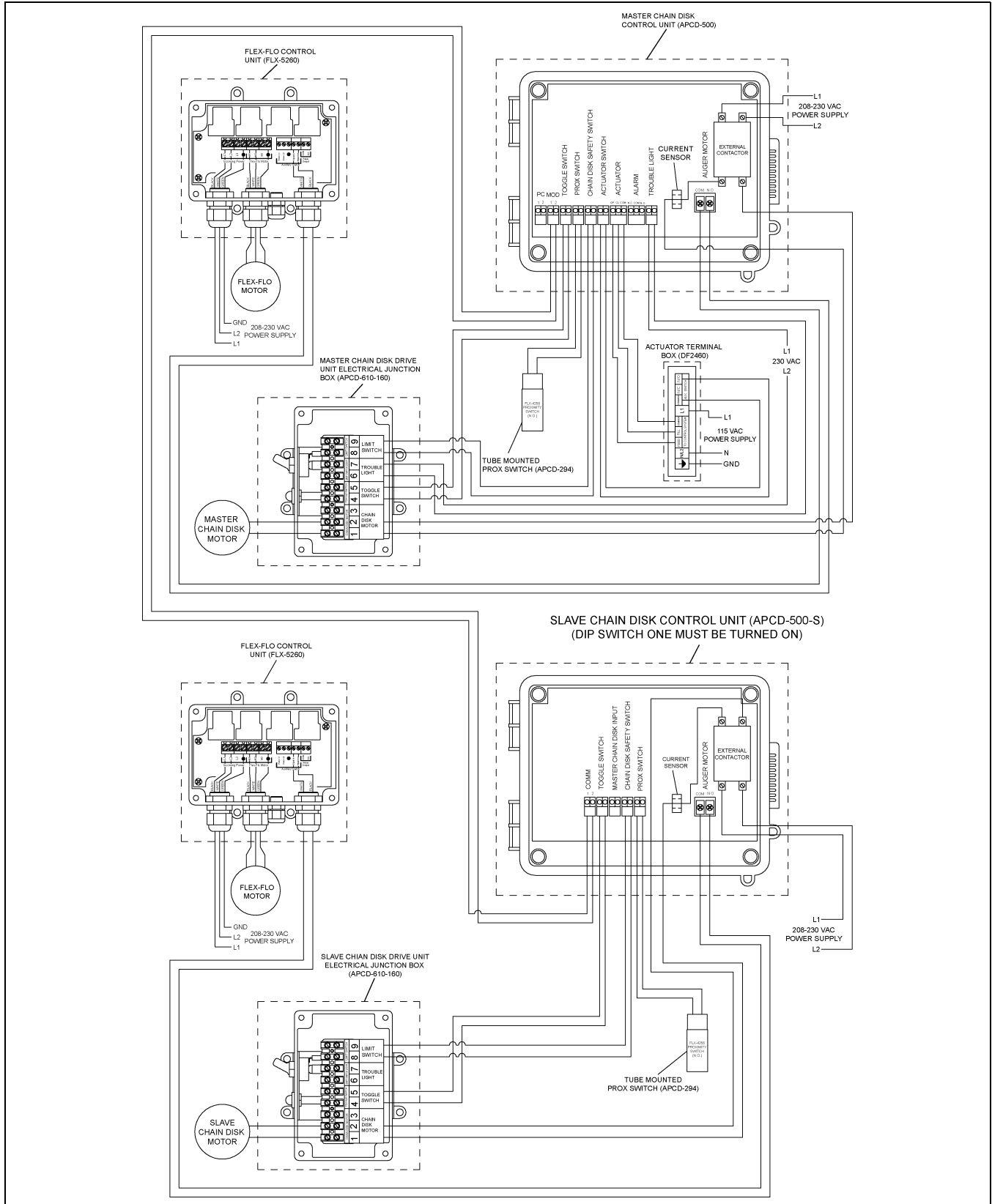

Figure 10B

Chain Disk with Display Control System (APCD-600)

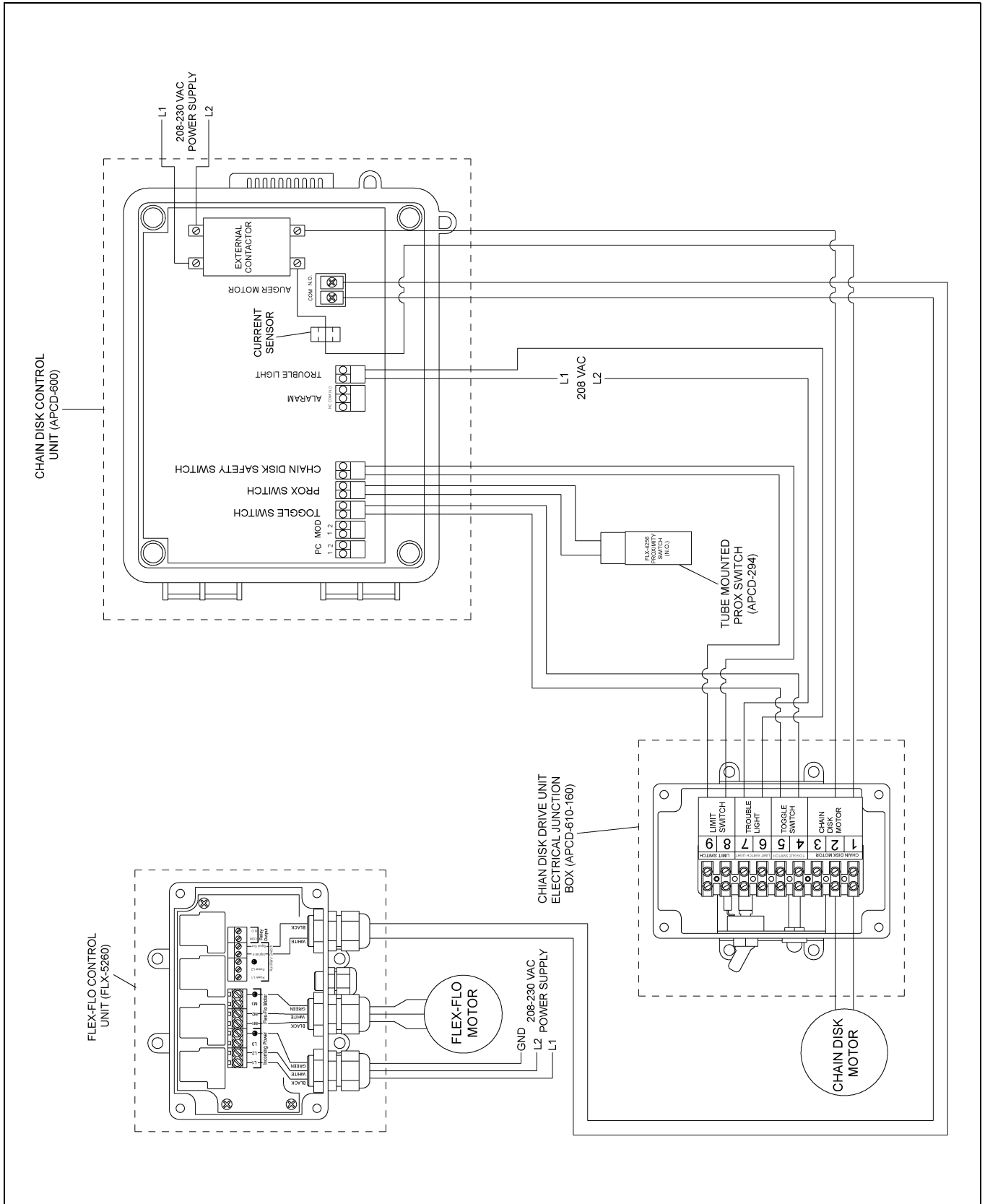

Figure 10C

Single Auger Single Loop System Illustration

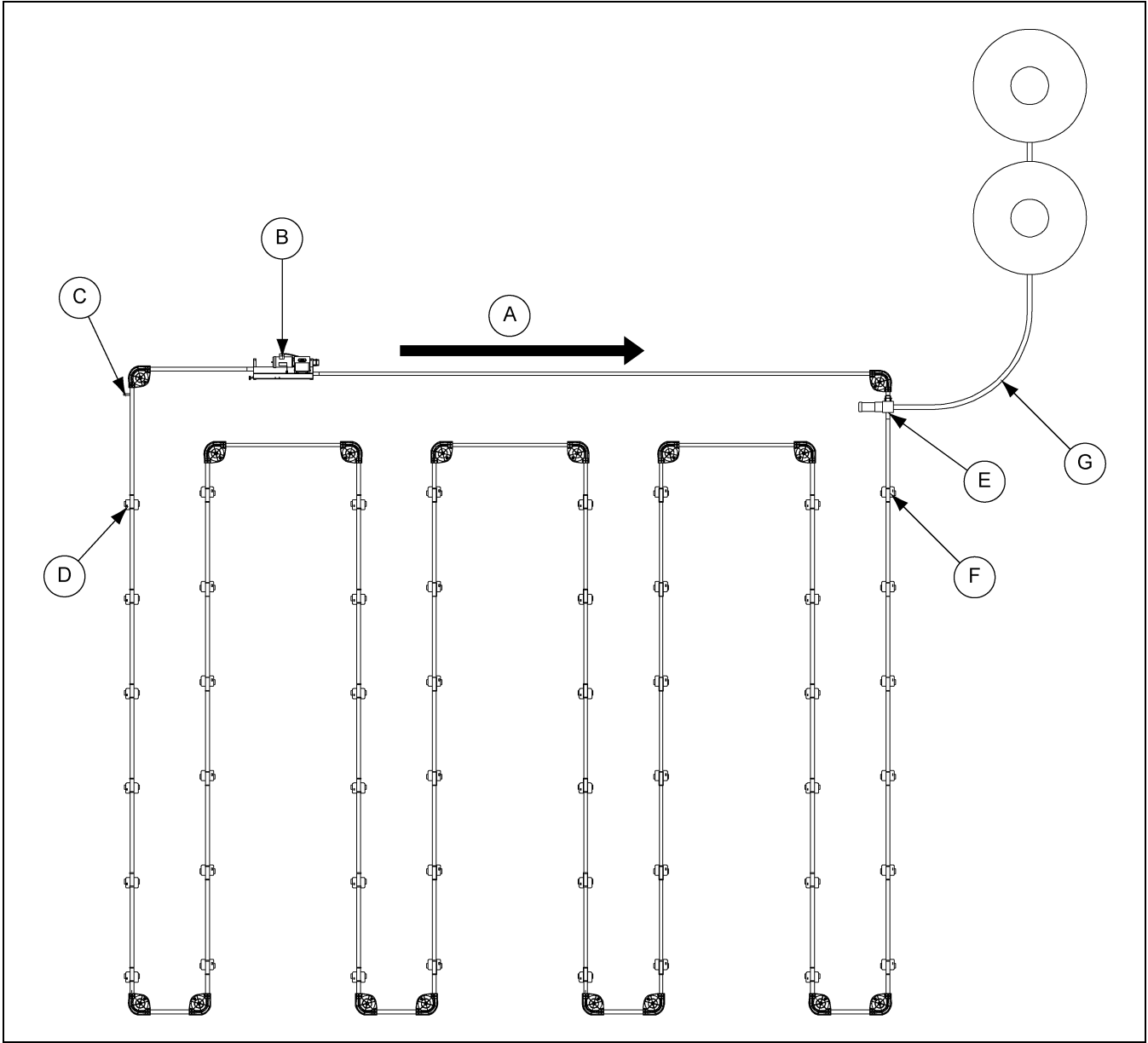

Figure 10D

Ref #	Description
A	Direction of Chain Travel
B	Chain Disk Drive Unit
C	Tube Mounted Proximity Switch
D	Last Feeder to be Filled
E	Flex-Flo Power Unit and Fill Hopper
F	First Feeder to be Filled
G	Model 300 Flex-Flo Auger

Single Auger Two (2) Loops System Illustration

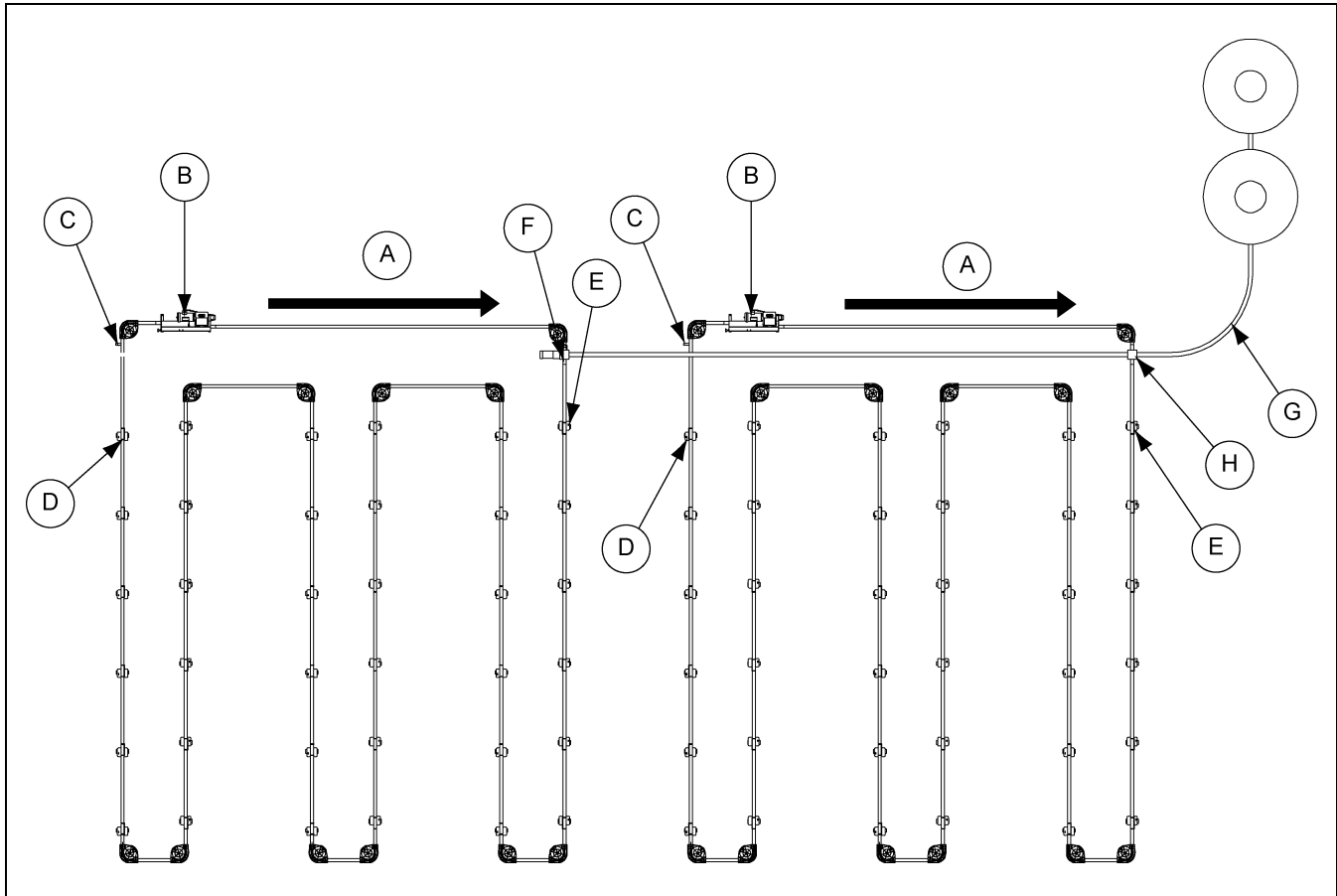

Figure 10E

Ref #	Description
A	Direction of Chain Travel
B	Chain Disk Drive Unit
C	Tube Mounted Proximity Switch
D	Last Feeder to be Filled
E	First Feeder to be Filled
F	Flex-Flo Power Unit and Fill Hopper
G	Model 300 Flex-Flo Auger
H	Model 300 Pass through Control and Fill Hopper

11. Operation Controls

Current Sensor

The Chain Disk System can over fill if the fill system's capacity is greater than the capacity of the Chain Disk System or if longer systems are allowed to re-circulate. Overfilling will overload the Chain Disk motor causing the thermal reset switch on the motor to kick out and/or premature motor failure. To prevent this from occurring a current sensor has been installed on the circuit board of the Chain Disk control unit.

This current sensor monitors the amp draw of the Chain Disk motor and controls a relay which has the fill system (Example: Flex-Flo) wired to it. While the Chain Disk System is filling, the amp draw of the motor will increase steadily. If the amperage reaches the maximum point of a specified range, the current sensor will automatically turn OFF the fill system temporarily. As the Chain Disk System continues to empty itself, the amp draw of the motor will decrease steadily. If the amperage reaches the minimum point of a specific range, the current sensor will automatically turn the fill system back ON. This ON/OFF cycling of the Flex-Flo will occur every few minutes until the Chain Disk feed system is full, at which time both the Chain Disk and Flex-Flo will shut OFF. (See Figure 11B on Page 37.)

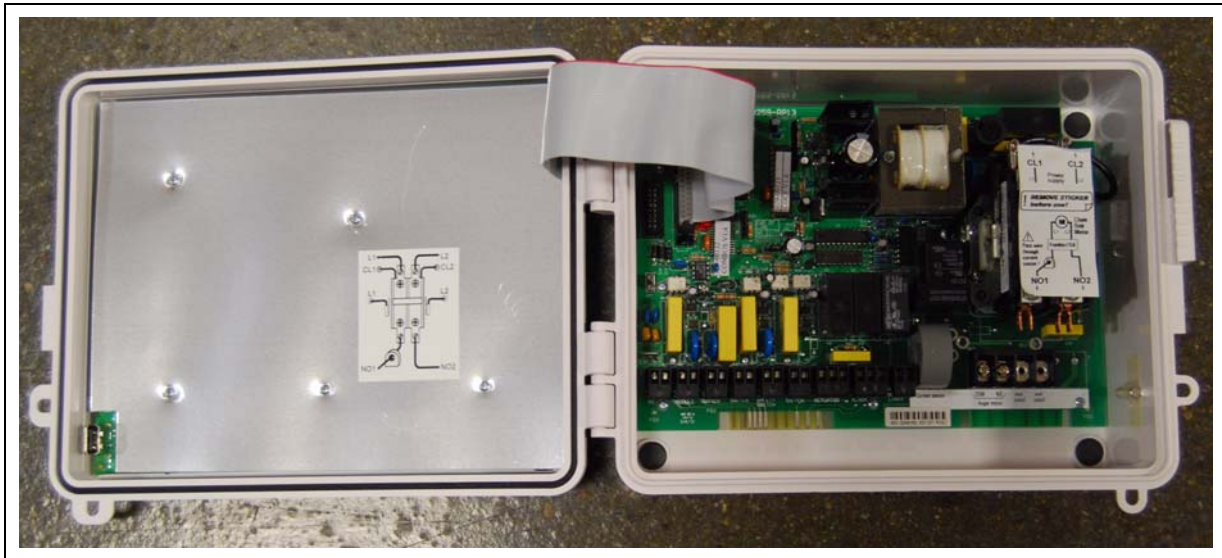

Figure 11A PC Board

Chain Disk Control Current Sensor Settings

Chain Disk Motor	Voltage	Recommended # of Loops through Current Sensor	Recommended Window Size	Suggested Maximum Current Sensor Setting for New Blue Gearbox*	Suggested Maximum Current Sensor Setting for Old Grey Gearbox**
Single Phase, 60 Hz	208-230	1	1.0	6.0	9.0
Single Phase, 50 Hz	190-230	1	1.0	6.0	9.0
Three Phase, 60 Hz	208-230	2	1.5	8.0	9.0
	460	3	1.0	6.0	7.0
Three Phase, 50 Hz	190	2	1.5	9.0	10.0
	230	2	1.5	8.0	10.0
	380	3	1.0	7.0	9.0

Critical amp setting should be 2 amps over maximum current sensor setting.

* New blue gearbox can only be used with 1.5 HP motor.

** Old grey gearbox can only be used with 2 HP motor.

Current Sensor (Continued)

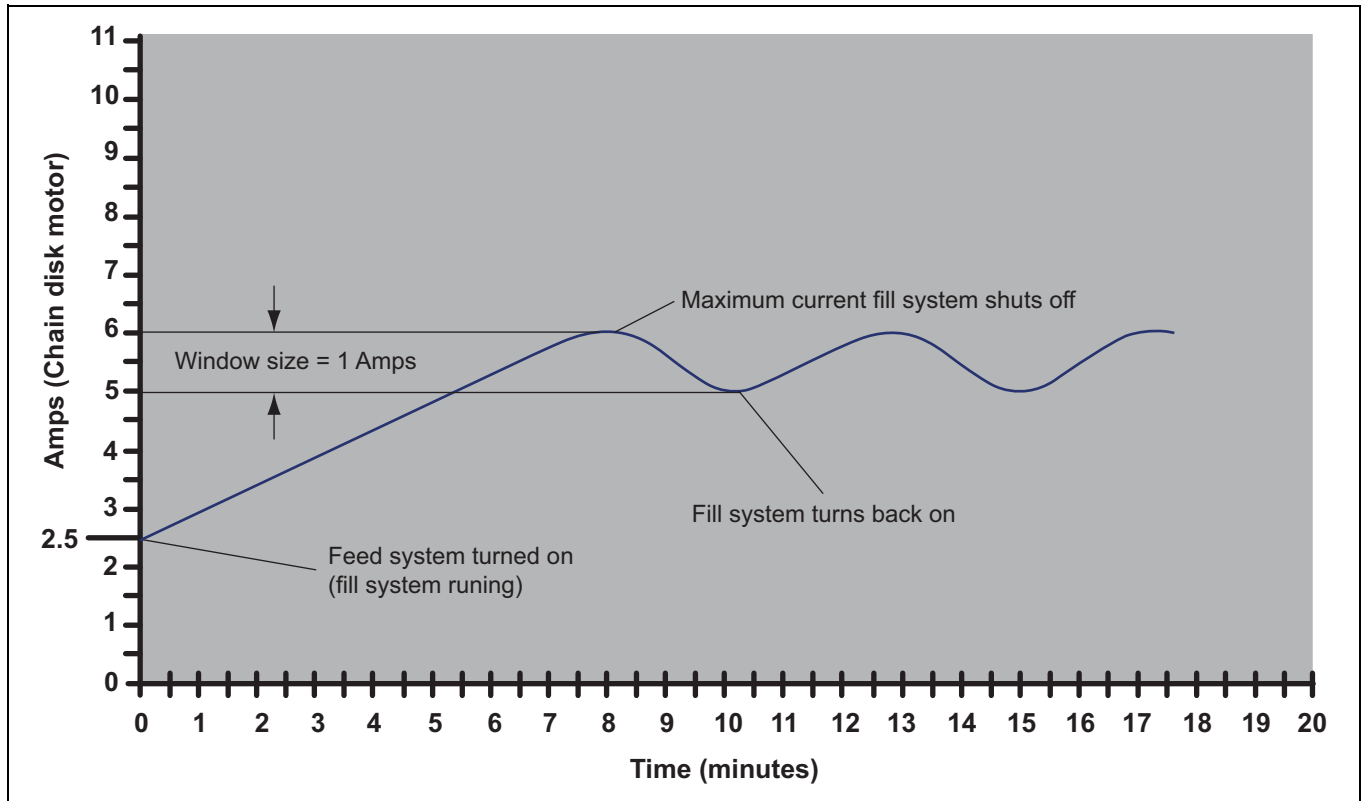

Figure 11B Graphical Illustration of Current Sensor Operation for Typical Feed System

Limit Switch

The limit switch ([See Figure 11C and Figure 11D on Page 38](#)), which is located in the Chain Disk drive unit, is used as a safety switch. The limit switch can be activated in either direction by a bracket which is connected to the idler wheel. It will shut the system down if the chain is too long or too short, if the chain or spring breaks or if something gets caught in the system. To re-activate the system, pull the blue reset button on the limit switch, reset the appropriate control unit by acknowledging the alarm on the APCD-500 control unit or push the reset button on the APCD-500-S control unit.

Limit Switch (Continued)

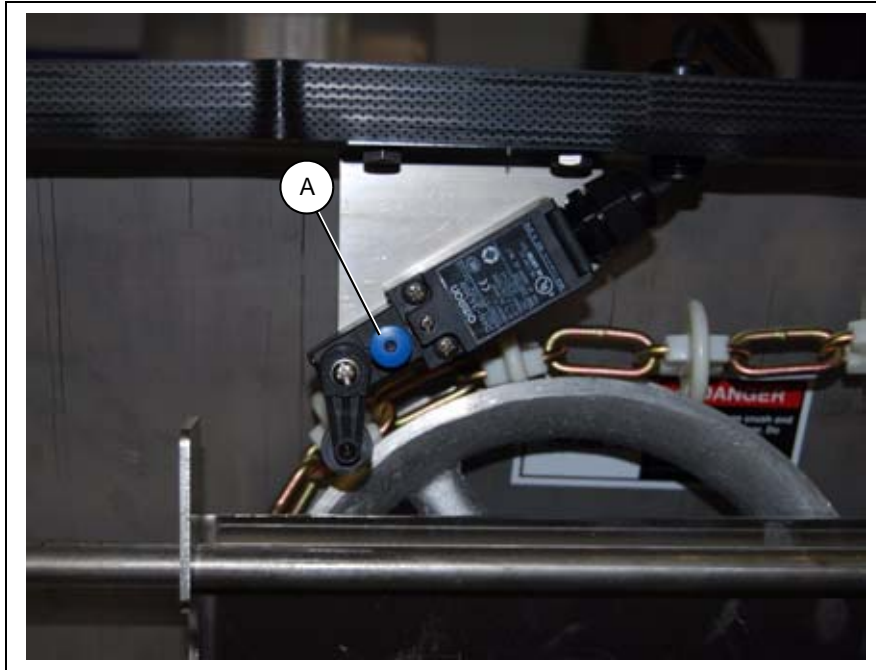

Figure 11C Limit Switch in Normal Operating State

Ref #	Description
A	Blue Reset Button

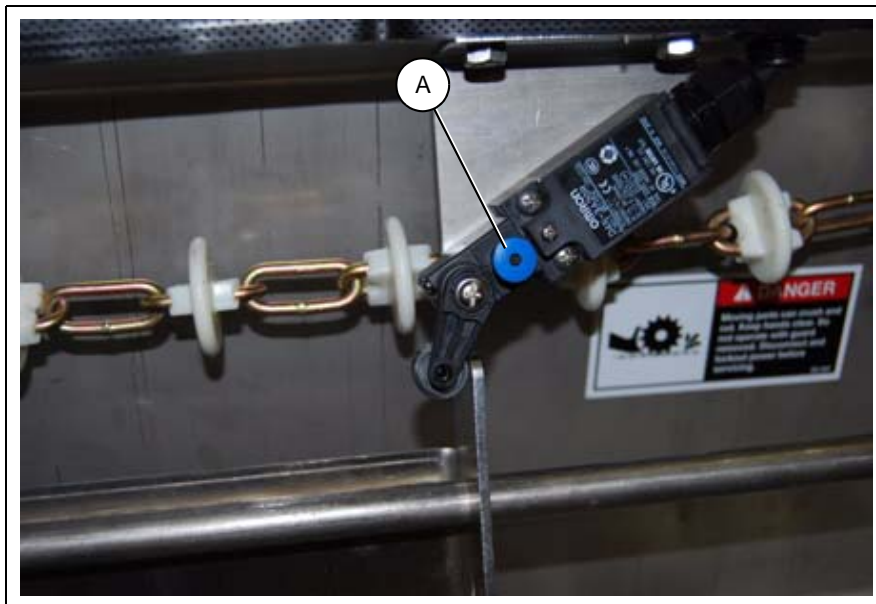

Figure 11D Limit Switch in Activated Shut Down State

Ref #	Description
A	Blue Reset Button

Limit Switch (Continued)



Disconnect power and fix the problem before pulling the reset button or acknowledge the alarm on the APCD-500 control.

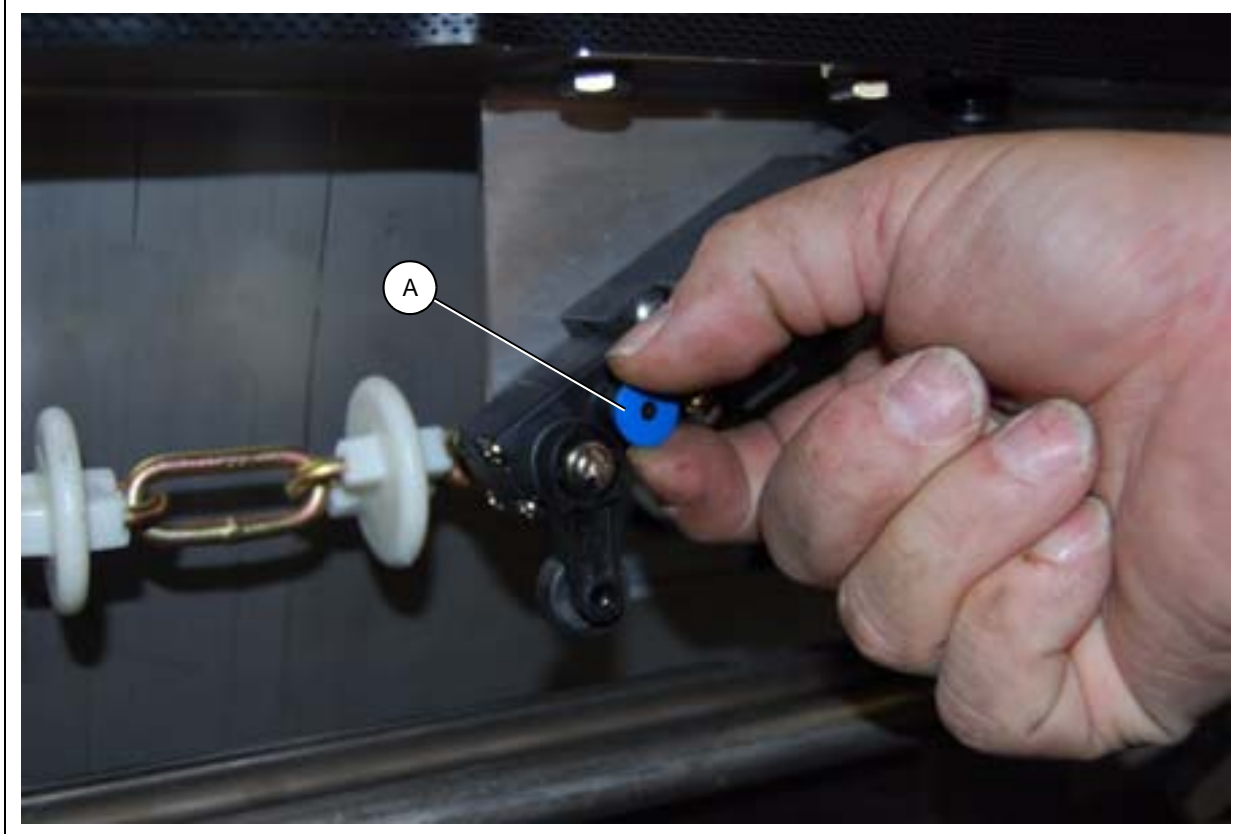

Figure 11E *Pulling the Reset Button*

Ref #	Description
A	Blue Reset Button

NOTE: *For operation, control settings and adjustment, see APCD-500, APCD-500-S and APCD-600.*



If a Flex-Flo System is used, turn the toggle switch to the OFF position.

Testing Limit Switch

With the motor turned on activate the limit switch in one direction. If the motor does not stop, refer to troubleshooting on [Page 68](#). To re-start, refer to [Page 37](#).

Check Drive Sprocket Rotation

Check to make sure the drive sprocket is turning counterclockwise as viewed from inside the drive unit. If not, rewire the wire connections to the motor according to the wiring connection diagram on the motor. (See Figure 13A.)



Figure 13A Chain and Disks with Connector Link

Pulling Chain through Tubing

NOTE: Fish tape required. (Length must be equal to or longer than the longest section of tubing.)

NOTE: You may want to mark or paint the linked sections, so they can easily be identified through a clear tube.



Inspect chain when installing to remove any kinks and knots from the chain. If kinks or knots get into system they can damage or break the disks. (See Figure 13B.)

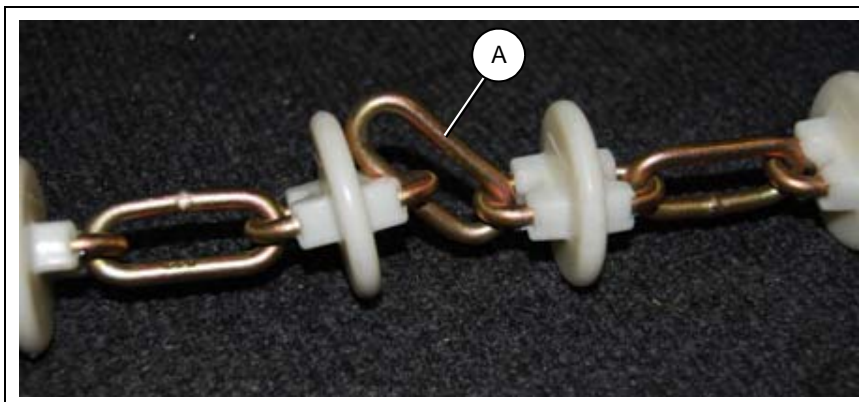

Figure 13B

Ref #	Description
A	Kinks

Pulling Chain through Tubing (Continued)

1. Start installing chain at one end of the drive unit so after all the chain is installed the final connection can be made inside the drive unit. (See [Figure 13C.](#))



Figure 13C

2. At the other end of the first section of tubing start pushing the fish tape through the tube until it comes out into the drive unit. (See [Figure 13D.](#))



Figure 13D

3. Connect one end of a section of chain and disks to the fish tape.
4. Pull the section of chain and disks through the tubing until there is only about 5' (1.5 m) left in the drive unit. If the section of tubing is longer than the chain and disks, use more than one section of chain and disks and connect them together using a connector link. (See [Figure 13A on Page 41.](#))

Pulling Chain through Tubing (Continued)

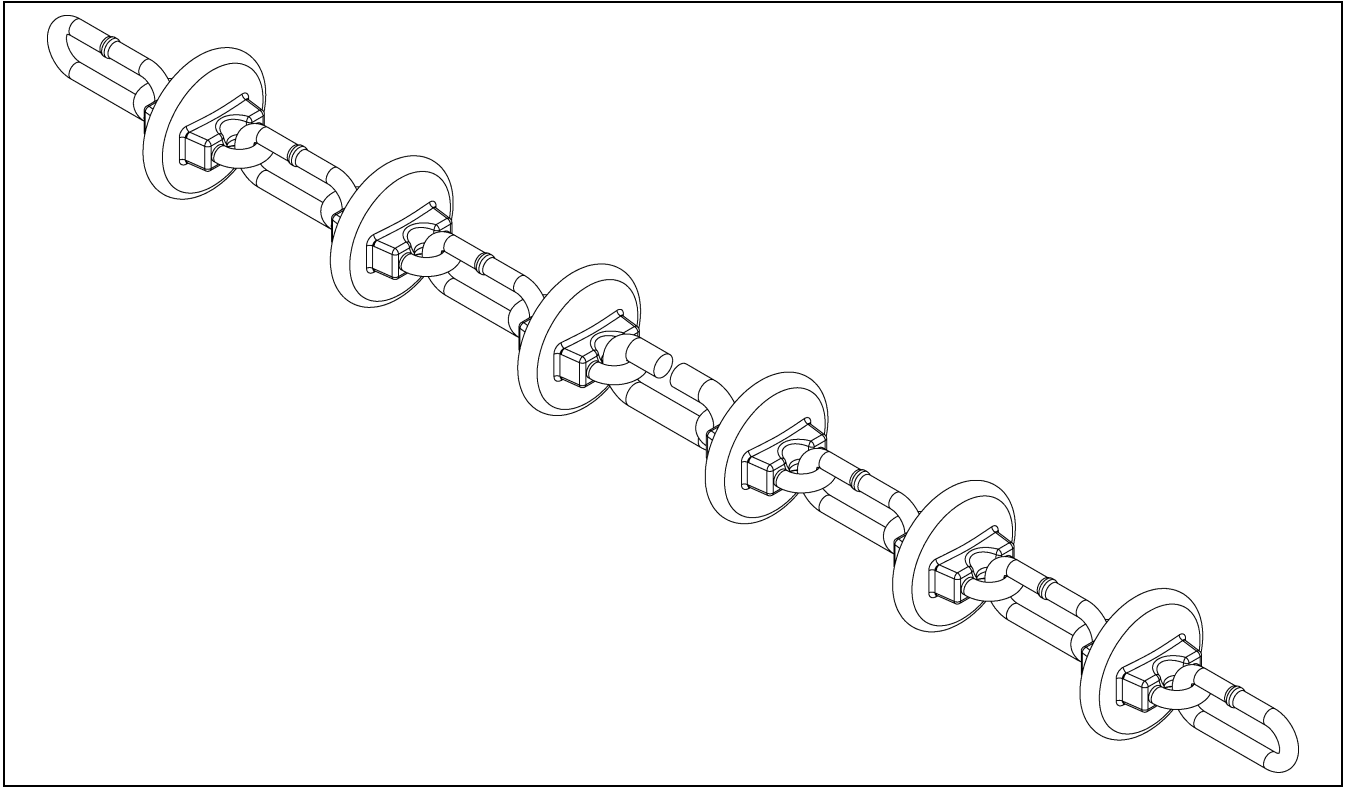

Figure 13E Coupling - Right

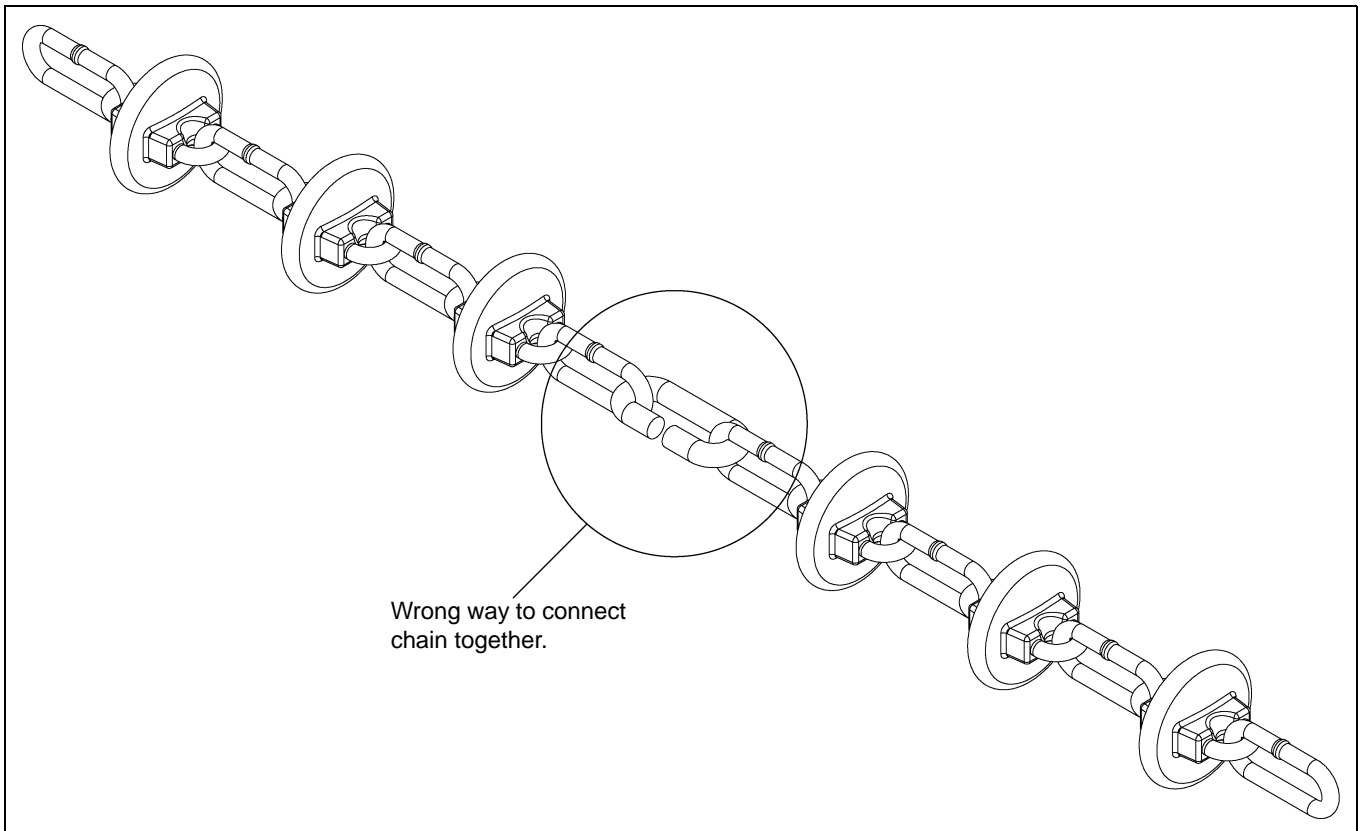

Figure 13F Coupling - Wrong

Pulling Chain through Tubing (Continued)

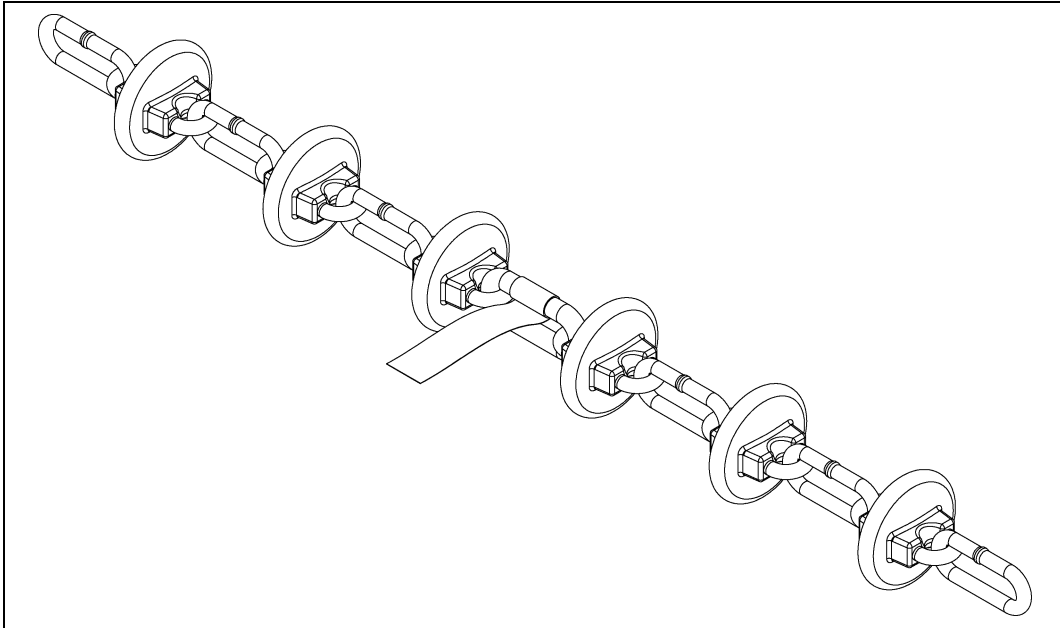

Figure 13G Coupling - Tape Correct

5. Go to the other end of the next section of tubing and start pushing the fish tape through the tube until it comes out this end of the tubing.
6. Connect one end of a new section of chain and disks to the fish tape. (See [Figure 13G.](#))
7. Pull the section of chain and disks through the tubing until there is only about 1' (1.5 m) left hanging out the tube.
8. Connect the two (2) sections of chain and disk together using a connector link. (See [Figure 13A on Page 41.](#))
9. Pull on the chain and disks until the slack is out of the section.
10. Connect the sections of tubing together.
11. Connections of chain and disk can be made at the corners as well.
12. Repeat [Step 4 on Page 42](#) through [Step 10 above](#) until all the chain and disks are pulled through the tubing.

Final Assembly of Corners



Before the final connection of the chain and disks is made in the drive unit the top on each corner must be replaced. Otherwise, the tension in the chain will warp the corner housings and make it difficult to replace the tops.

1. Remove the 1/2" lock nut and 1/2" neoprene backed flat washer which were placed on the pivot shaft previously. (See [Figure 8A on Page 26](#) and [Figure 8B on Page 27.](#))
2. Connect the top to the corner using 5/16" x 1-1/4" bolts and 5/16" nuts. Torque hex nuts to 5 ft. lbs. (DO NOT OVERTIGHTEN.)
3. Replace the 1/2" neoprene backed flat washer and 1/2" lock nut on the pivot shaft. Torque lock nut to 10 ft. lbs. (DO NOT OVERTIGHTEN.)

Installing Chain into Drive Unit

1. Unhook both springs inside the drive unit. (See [Figure 13H-Figure 13J below and Page 46.](#))
2. Slide the idler wheel until it is as close to the drive sprocket as possible.
3. Wrap one end of the chain and disks around the idler wheel and the other around the drive sprocket as shown in [Figure 13H-Figure 13J below and Page 46.](#) The fan end of the motor has a shaft extension with flat sides which can be turned with a 1/2" wrench to thread the chain and disks around the drive sprocket. Remove the plastic protector cap to expose the motor shaft extension.
4. Cut the two (2) ends of the chain and disks so that the connection can be made in a convenient location.
5. Connect the ends using a connector link. (See [Figure 13H-Figure 13J below and Page 46.](#))
6. Re-hook both springs using the "T" handle knobs.
7. Put the drive unit cover ON.

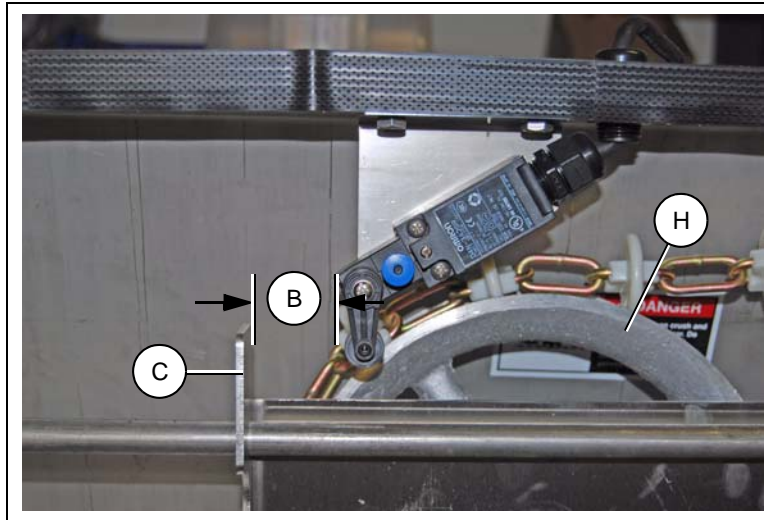

Figure 13H

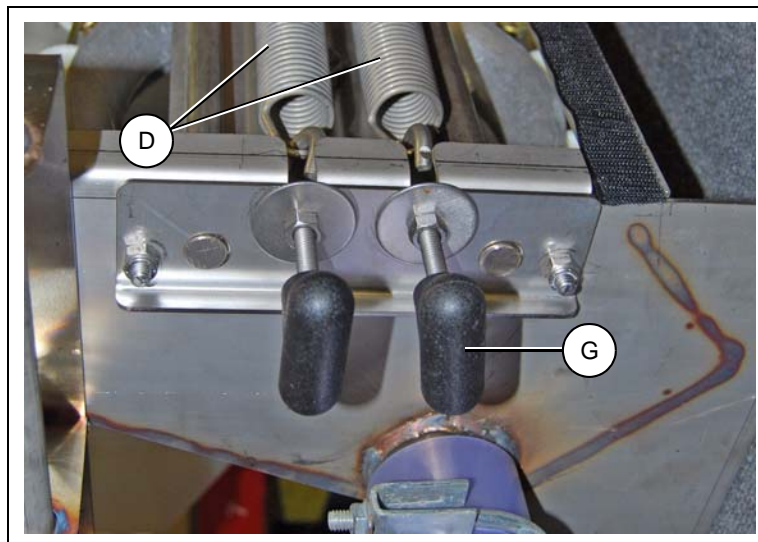

Figure 13I

Installing Chain into Drive Unit (Continued)

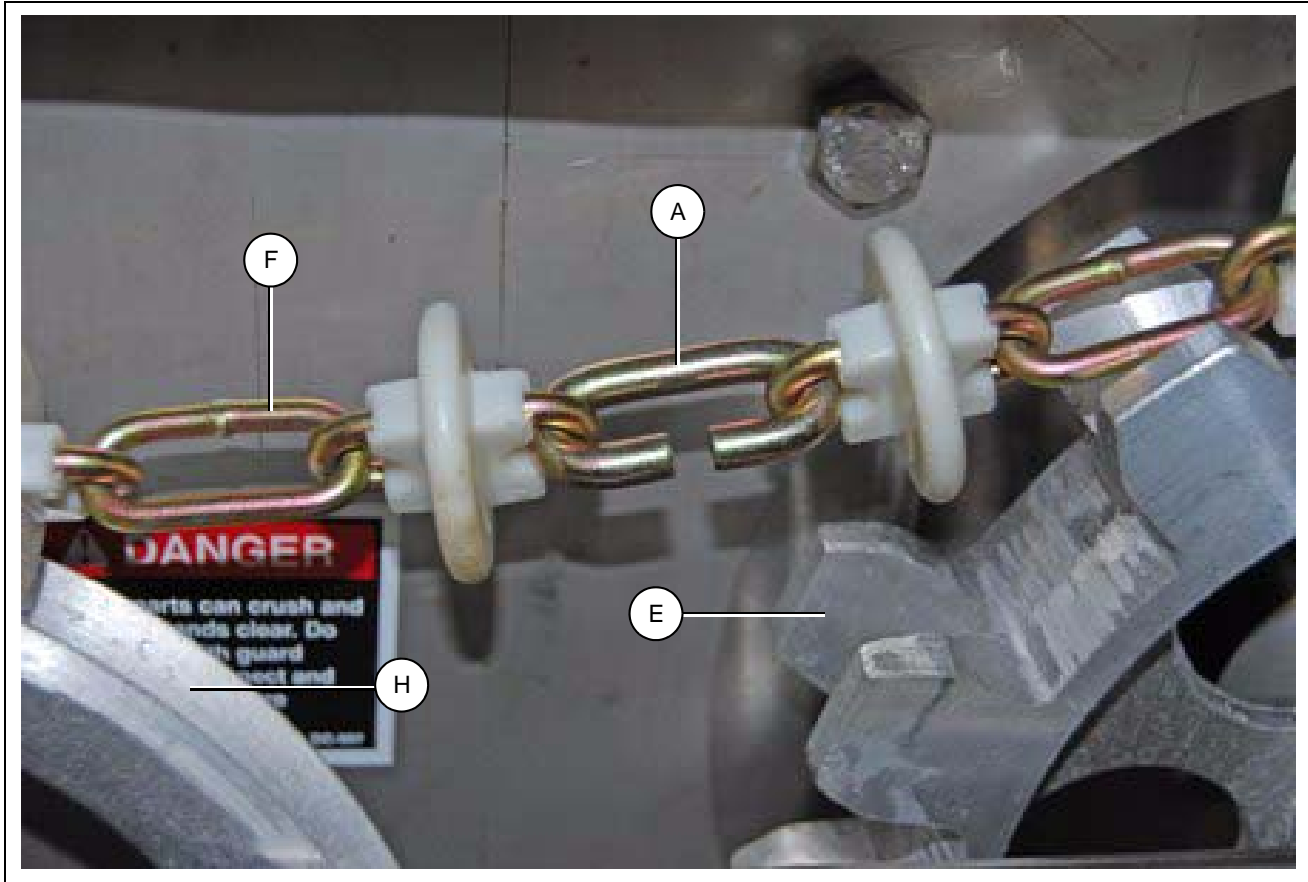

Figure 13J

Ref #	Description
A	Connector Link
B	2"
C	Left Limit Switch Tab
D	Spring (2)
E	Drive Sprocket
F	Chain and Disks
G	"T" Handle Knobs (2)
H	Idler Wheel

Chain Take-Up

1. Run the Chain Disk System for 10-15 seconds.
2. Disconnect all electrical power.
3. Remove drive unit cover.
4. Check to see that the limit switch is not contacting the limit switch tab. In the process of breaking in the chain and disks, the chain will lengthen causing the limit switch tab to move to the left eventually hitting the limit switch and shutting down the system. If the limit switch tab has moved to the left or has already hit the limit switch, links of chain need to be taken out of the system.

Refer to installing chain [Steps 1 to 7 on Pages 42 and 44](#).

NOTE: Always remove twice as much chain as the idler wheel needs to move. As an example, if the idler wheel should move 4" to the right, remove 8" of chain.

5. Connect all electrical power.
6. Repeat [Steps 1-4 above](#) until the limit switch stays approximately 2" from the left limit switch tab as shown in [Figure 13H-Figure 13J on Pages 45 and 46](#). Increase the time that the system runs each time these steps are repeated until the system has run for at least 10 minutes.

Mounting Proximity Switch

1. Mount proximity switch to a CLEAR section of tubing located after the last drop tube and before the drive unit. ([See Figure 13K.](#))
2. Attach the proximity switch mounting bracket to the clear tubing using the hose clamps provided. Adjust the bracket so the proximity switch is mounted at a 45° angle. ([See Figure 13K.](#))

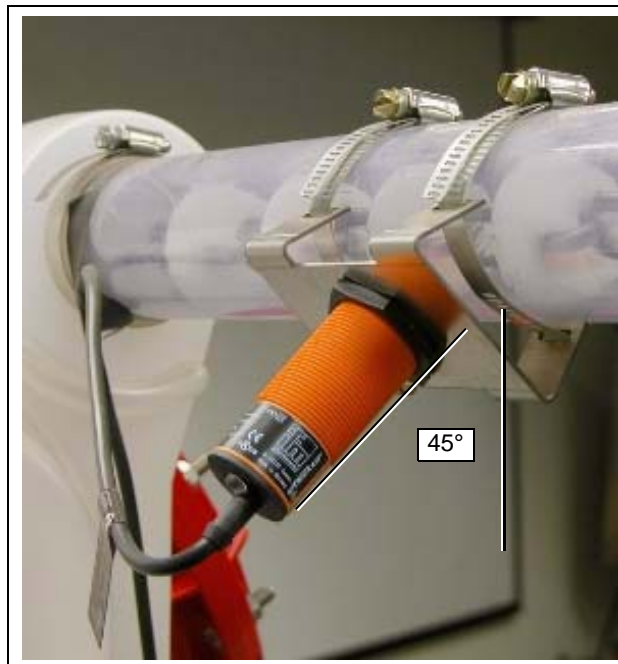

Figure 13K

3. The proximity switch must touch the clear tube. Adjust the top plastic nut until the top of the switch is touching the tube. Adjust the bottom plastic nut to secure into place. ([See Figure 13L on Page 48.](#))

Mounting Proximity Switch (Continued)

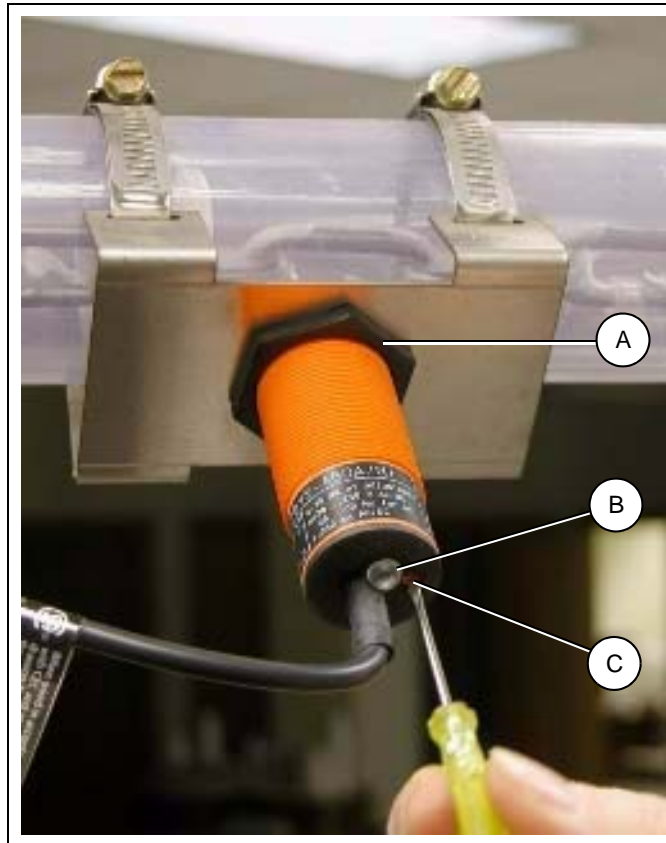

Figure 13L

Ref #	Description
A	Bottom Plastic Nut
B	Indicator Light
C	Sensitivity Adjustment Screw

Adjusting Sensitivity

1. Turn OFF the flex auger so no feed is being added to the line.
2. Turn Chain Disk on in Manual Mode and clear all feed from inside of line. You may want to adjust the feed sensor bypass time to allow the line to run longer during setup.
3. If the light is ON when the tube is empty, the switch is too sensitive. You must reduce the sensing distance by turning the sensitivity adjustment screw counterclockwise. To increase the sensing distance adjust the screw clockwise. (See Figure 13L.)
4. To set the correct sensitivity, place your index finger on the tubing so it is 1/4" from the sensing end of the proximity switch. Then turn the sensitivity adjustment screw until the indicator light turns ON. The light may be ON solid or may just blink when a disk passes by. Either setup is fine.

NOTE: Make sure that you have your fist closed with only your index finger open. Also, do not touch the tube with the other hand or leave anything laying over the tube to interfere with the sensitivity. (See Figure 13M and Figure 13N on Page 49.)

Adjusting Sensitivity (Continued)

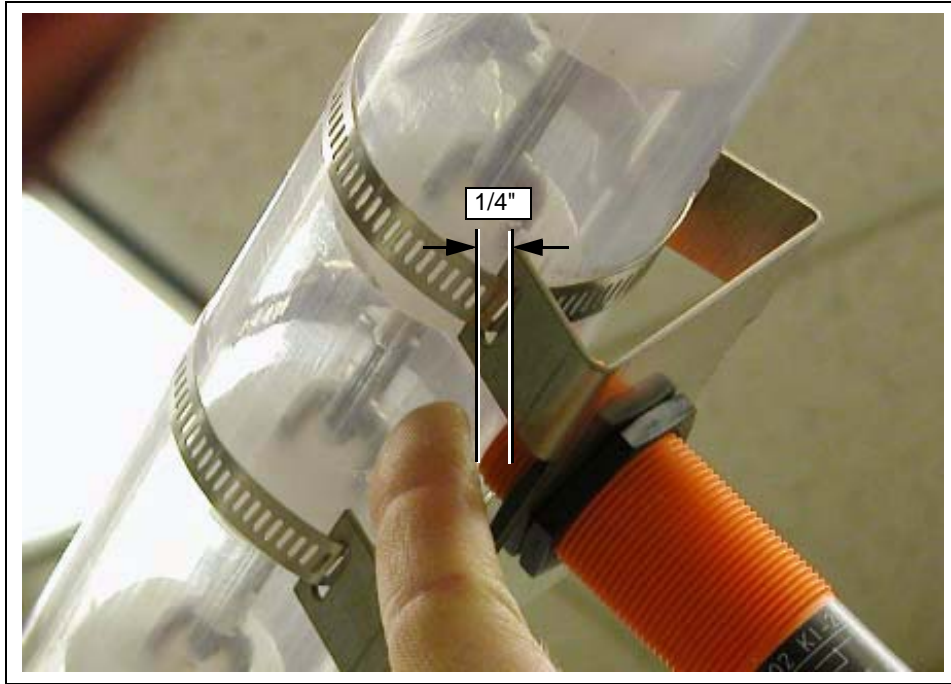

Figure 13M

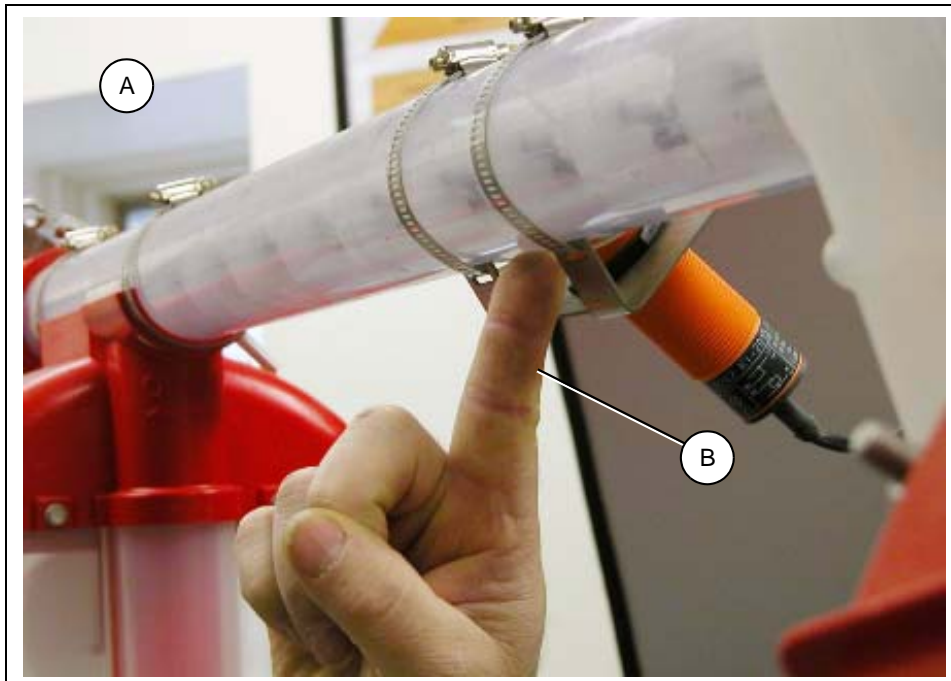

Figure 13N

Ref #	Description
A	Clear Area Around Tube
B	Index Finger with Closed Fist

5. Reset the feed sensor bypass time if it was changed for setup.



Always disconnect power before removing any covers from equipment.

Chain and Disk Tension

Check the tension in the chain and disk monthly. If the limit switch tab is close to the limit switch, see “chain take-up”, [Steps 2-6 on Page 47](#) on how to remove a section of chain.

Remember to always remove twice as much chain as the distance the idler wheel needs to move to the right.

Gearbox Maintenance Free

1. This gearbox is a high efficiency gearbox that runs extremely cool. The cooler temperature prevents seals from degrading.
2. The gearbox is sealed for life. No need to check or add fluid.

Bushing Replacement in Idler Wheel

Check nylon bushings (APCD-007) in main drive idler wheel annually. If bushings show excessive wear contact manufacturer for replacements. Refer to parts list on [Page 53](#) for a drawing of this bushing.

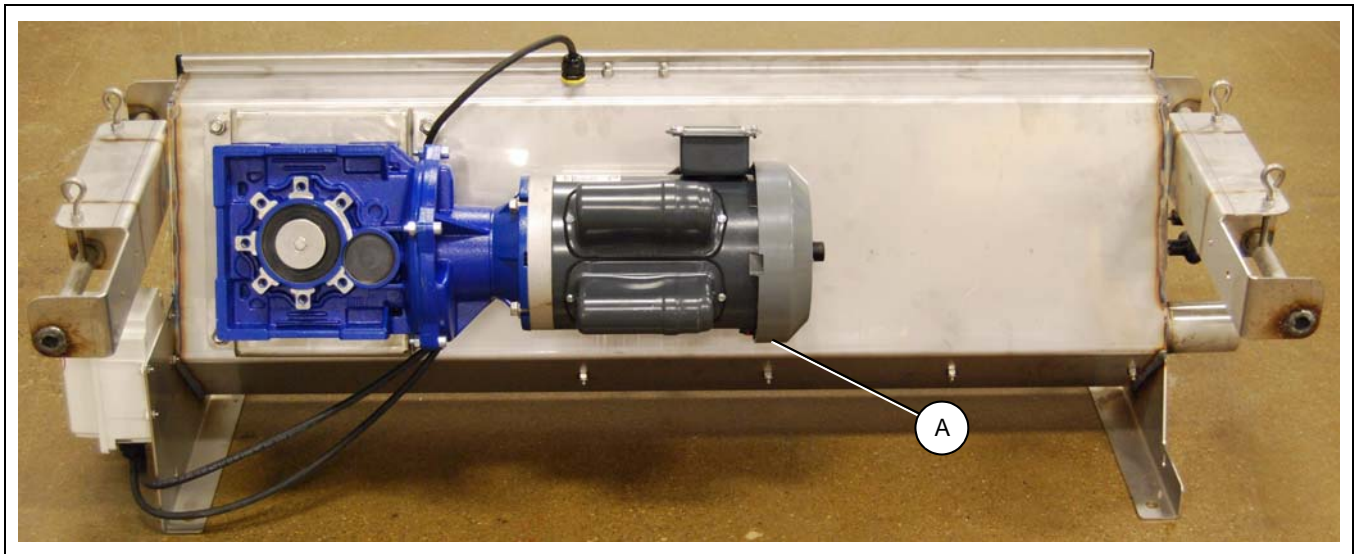

Figure 14A *Back of Control Unit*

Ref #	Description
A	Motor Overload Reset Button

Limit Switch Inspection

Check the operation of the limit switch in drive unit monthly.

1. Disconnect power and remove drive unit cover.
2. Activate the limit switch in one direction.
3. Replace cover and turn ON power.
4. Turn the Chain Disk control to the manual start position. If the Chain Disk safety switch and alarm indicator light do not come ON; disconnect power, inspect wiring and limit switch and replace if necessary. If the alarm indicator light comes ON then the switch is working properly.
5. Turn the Chain Disk control to the manual stop.
6. The Chain Disk is now ready for normal operation.

NOTES

1. Proximity Feed Sensor for Clear PVC Tube - [\(See Page 54.\)](#)
2. Horizontal Corner Installation and Suspension (APCD-708) - [\(See Page 55.\)](#)
3. Vertical and Inclined Corner Installation and Suspension (APCD-703) - [\(See Pages 56-57.\)](#)
4. Chain Disk Drive Unit (APCD-610-150, APCD-610-160 and APCD-610-350) - [\(See Pages 58-61.\)](#)
5. Fill Hopper Assembly - [\(See Page 62.\)](#)
6. PVC - Clear - [\(See Page 63.\)](#)
7. PVC - White - [\(See Page 63.\)](#)
8. Welded Steel Tubing - [\(See Page 64.\)](#)
9. Drop Kits - [\(See Page 65.\)](#)
10. Chain Disk Control Unit - [\(See Pages 66-67.\)](#)

Proximity Feed Sensor for Clear PVC Tube

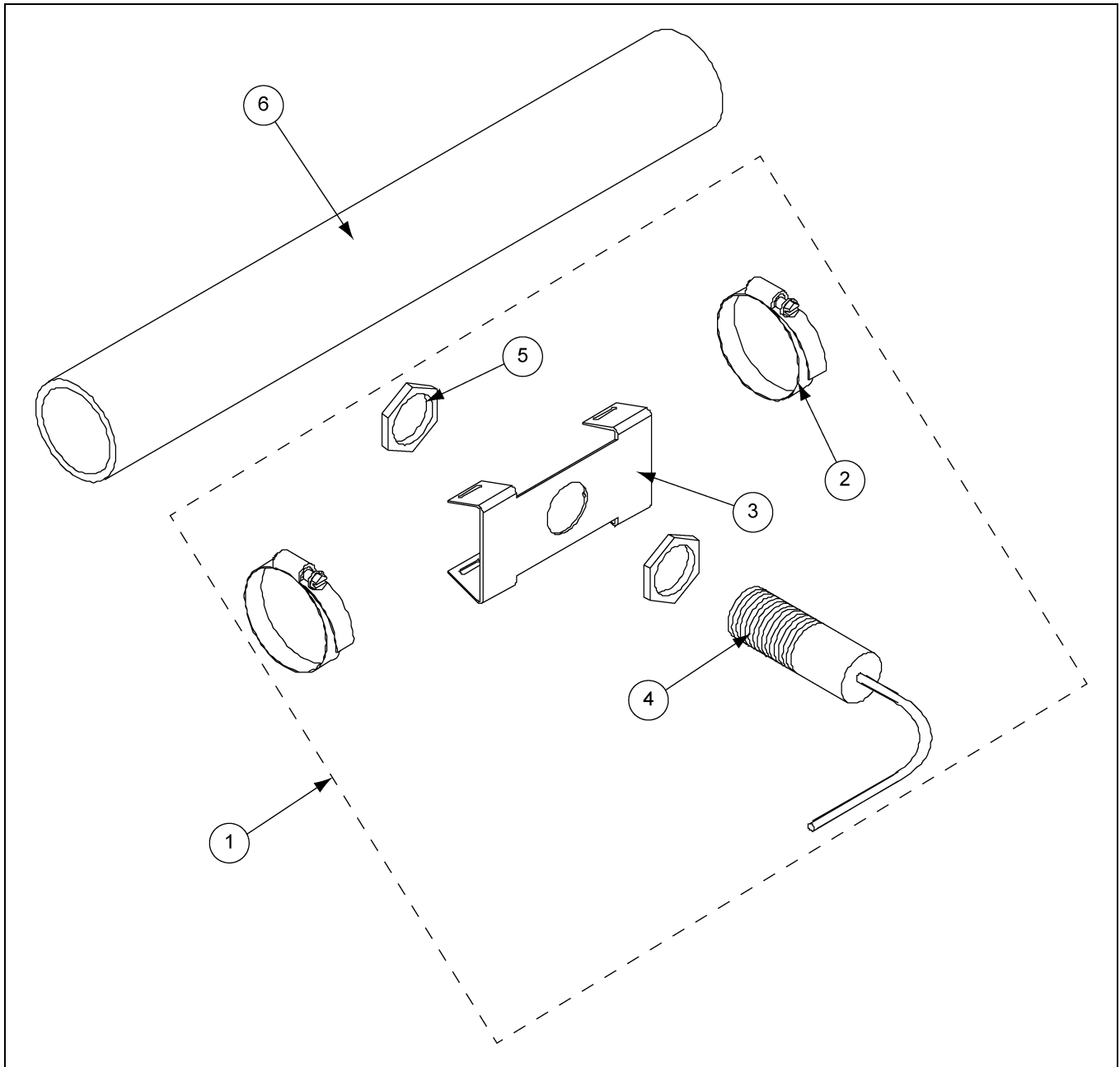

Proximity Feed Sensor for Clear PVC Tube Parts List

Ref #	Part #	Description	Qty
1	APCD-294	Proximity Feed Sensor for Tube 220V	
2	AP-0583	Clamp, Hose, Stainless Steel 1-13/16" to 2-3/4"	2
3	APCD-136	Proximity Switch Mounting Bracket	1
4	FLX-4256	Proximity Switch N.O. 20-250 VAC	1
5	FLDX-1172N	Proximity Switch Mounting Nut	2
6	APCD-104	Tube, Model 236 Clear PVC, 10' Sections	

Horizontal Corner Installation and Suspension (APCD-708)

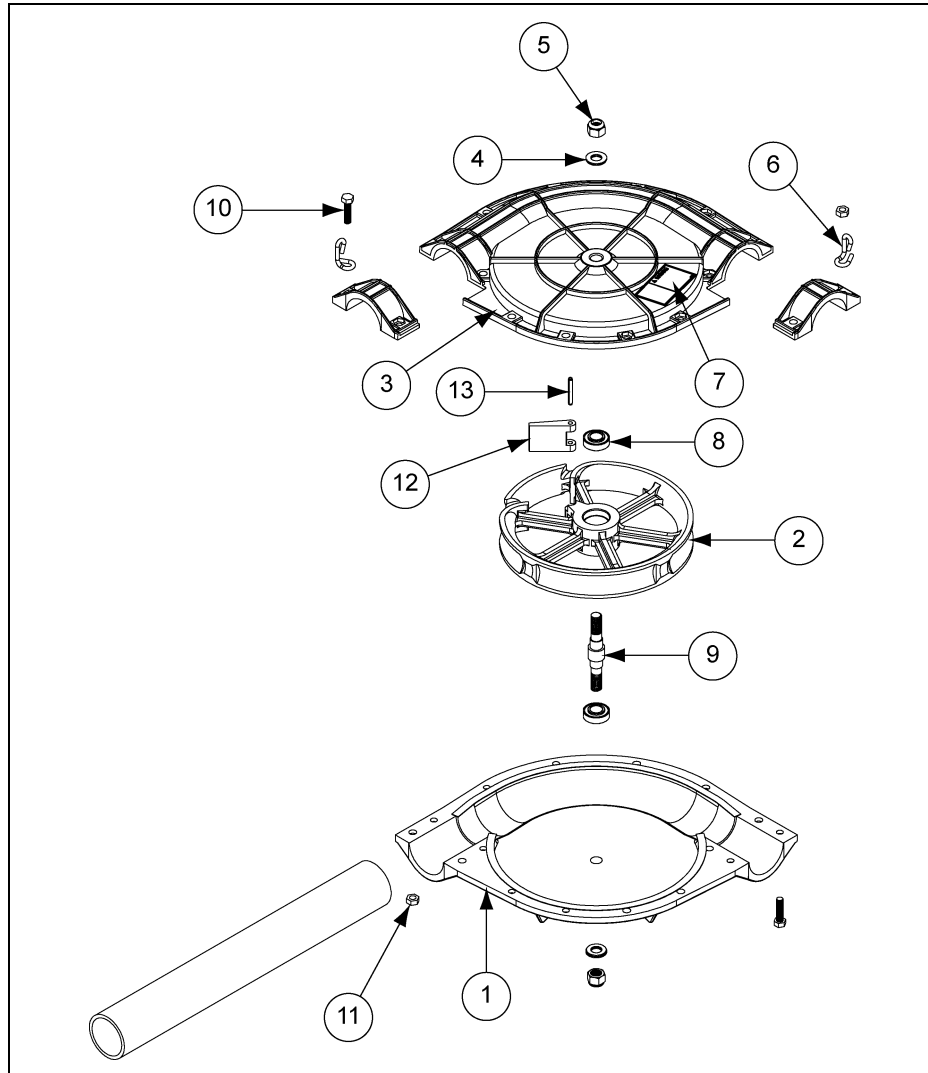

Horizontal Corner Installation and Suspension (APCD-708) Parts List

Ref #	Part #	Description	Qty
1	APCD-001P	90° Chain Disk Corner Bottom Half - Clear	1
2	APCD-713	Self-Cleaning Corner Wheel Assembly	1
3	APCD-000P	90° Chain Disk Corner Top, Half - Clear	1
4	S-9379	Washer, 1/2" Neoprene Backed SS	2
5	S-7417	Nylock Nut 1/2" 13 SS	2
6	APCD-313	Wire Suspension Angle	2
7	DC-1244	Decal, Warning Chain Disk Corner	1
8	APCD-330	Bearing, Corner Idler Wheel	2
9	APCD-327	Shaft, Corner Idler Wheel	1
10	S-7683	Bolt, HHCS 5/16"-18 x 1-1/4" SS	16
11	S-8452	Flange Nut 5/16"-18 SS Waxed	16
12	APCD-430B	Flipper for Self-Cleaning Corner Wheel	1
13	S-7184	Spring Pin 3/16" x 1-1/2" Long Roll Spring Pin Zinc	1

Vertical and Inclined Corner Installation and Suspension (APCD-703)

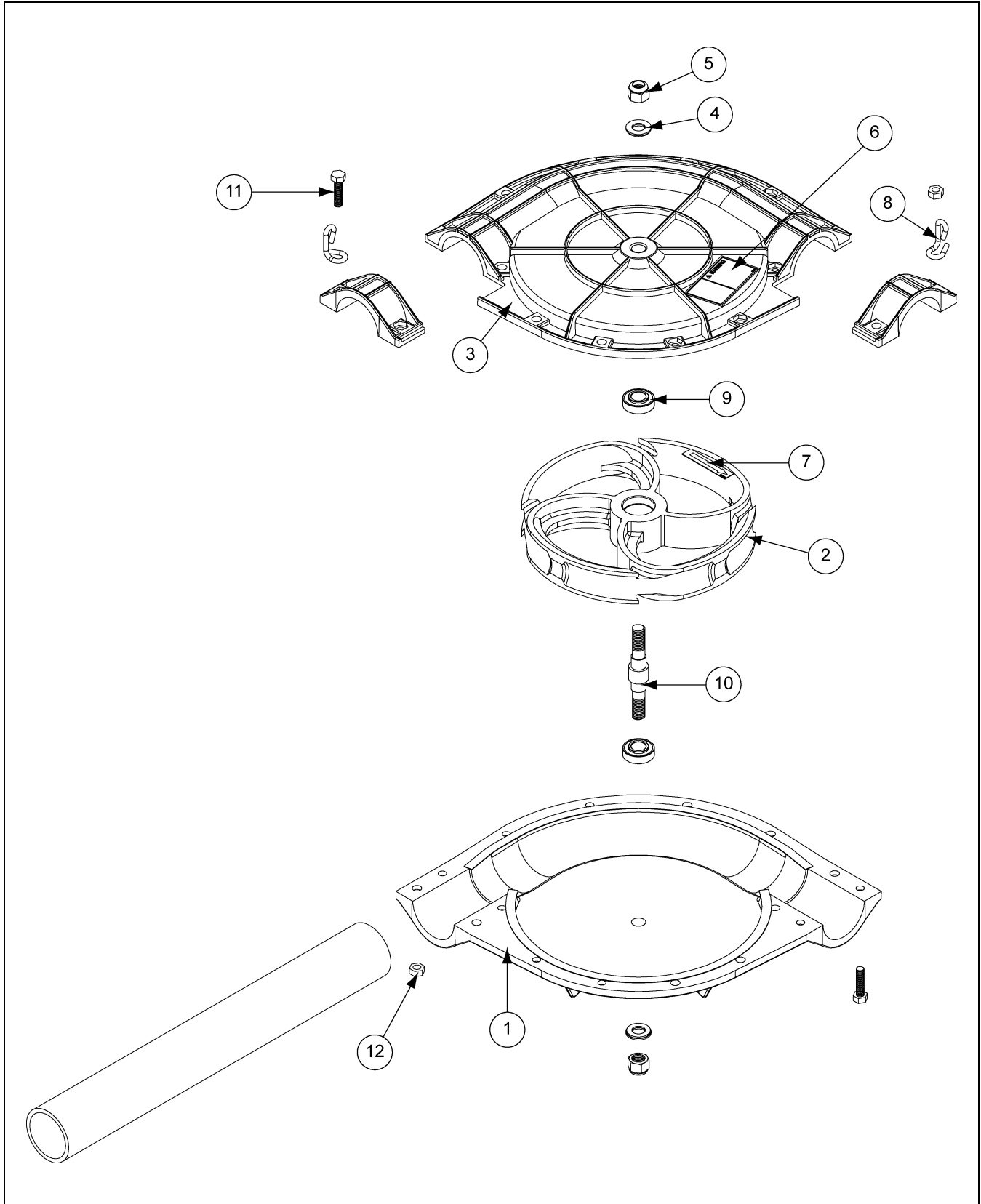

Vertical and Inclined Corner Installation and Suspension (APCD-703) Parts List

Ref #	Part #	Description	Qty
1	APCD-001P	90° Chain Disk Corner Bottom Half - Clear	1
2	APCD-702C	Vertical Corner Wheel Assembly with Steel Cast Wheel	1
3	APCD-000P	90° Chain Disk Corner Top, Half - Clear	1
4	S-9379	Washer, 1/2" Neoprene Backed SS	2
5	S-7417	Nylock Nut 1/2"-13 SS	2
6	DC-1244	Decal, Warning Chain Disk Corner	1
7	DC-5132	Decal, Red Arrow (Direction)	2
8	APCD-313	Wire Suspension Angle	2
9	APCD-330	Bearing, Corner Idler Wheel	2
10	APCD-327	Shaft, Corner Idler Wheel	1
11	S-7683	Bolt, HHCS 5/16"-18 x 1-1/4" SS	16
12	S-8452	Flange Nut 5/16"-18 SS Waxed	16

Chain Disk Drive Unit (APCD-610-150, APCD-610-160 and APCD-610-350)

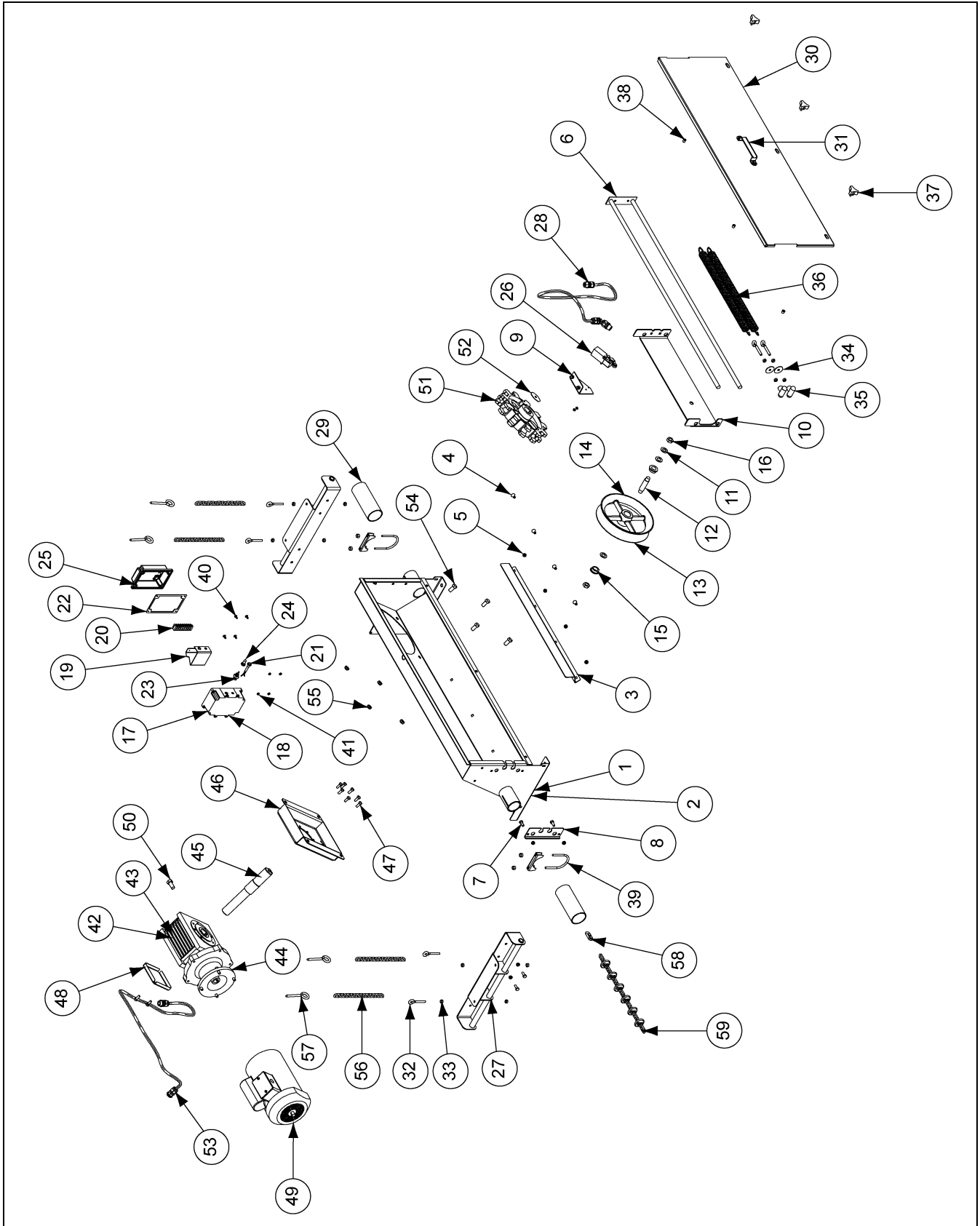

Chain Disk Drive Unit (APCD-610-150, APCD-610-160 and APCD-610-350) Parts List

Ref #	Part #	Description	Qty
1	APCD-609	Trough Assembly, Chain Disk Drive Unit	1
2	APCD-412	Trough Assembly	1
3	APCD-398	Chain Disk Inlet Trough	1
4	S-8451	Carriage Bolt 5/16"-18 x 3/4" SS	4
5	S-7356	Esna Nut 5/16"-18 SS	14
6	APCD-346	Idler Rod Assembly	1
7	S-7821	Bolt, HHCS 5/16"-18 x 3/4" SS	10
8	APCD-369	L.H. End Panel Stiffener	1
9	APCD-349	Limit Switch Bracket	1
10	APCD-414	Idler Slide Bracket	1
11	S-7999	Flat Washer 5/8" x 1-3/16" O.D. SS	3
12	APCD-154	Shaft, Drive Unit Idler Wheel	1
13	APCD-012	Wheel Assembly Idler with Bushings	1
14	APCD-010	Wheel Main Drive Idler Machined	1
15	APCD-007	Bushing, Main Driver Idler	2
16	S-7998	Jam Nut 5/8"-11 SS	2
17	APCD-249	Electrical Box Assembly	1
18	APCD-181	Electrical Box - Drilled	1
19	APCD-138	Terminal Block Mounting Bracket	1
20	S-8042	Terminal Block 9 Connector	1
21	S-7604	Light 250V Sealed Red Pilot	1
22	FLX-4561S	4" x 6" Electrical Box Gasket	1
23	20-5060	Switch, Toggle SPST 15A with ON/OFF	1
24	70-0129	Boot Switch Weatherproof	1
25	FLX-4560	Electrical Box Lid 4" x 6"	1
26	APCD-715	Limit Switch with Metric watertight Fitting	1
27	APCD-382	Suspension Angle Assembly	2
28	APCD-604	Cord Limit Switch Long Drive	1
29	APCD-105	Coupler, Model 236 Clear PVC	2
30	APCD-350	Door Chain Disk Long Drive	1
31	PR-331	Peak Cap Handle	1
32	S-8191	Eye Bolt 5/16"-18 x 2-1/4" SS	6

Chain Disk Drive Unit (APCD-610-150, APCD-610-160 and APCD-610-350) (Continued)

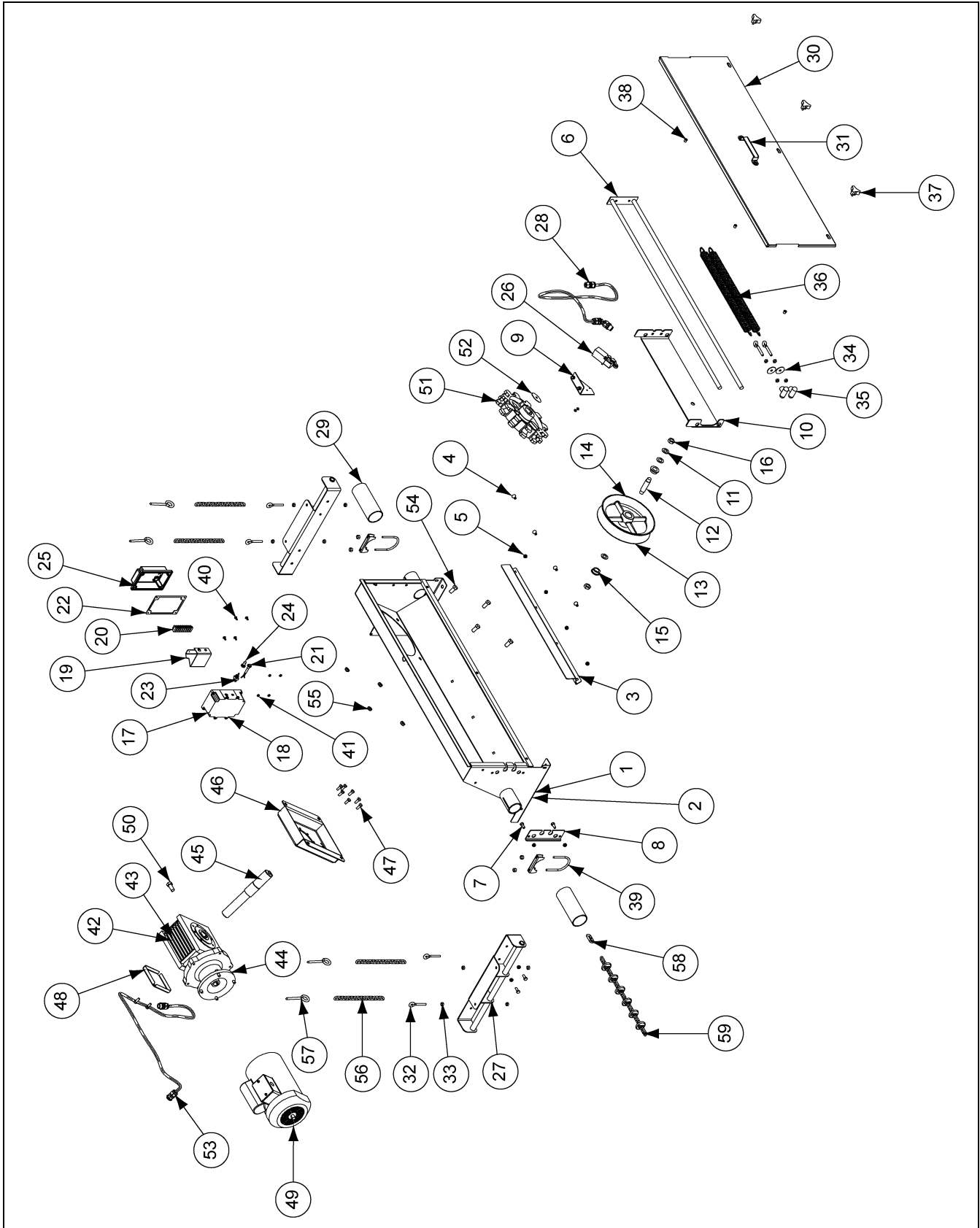

**Chain Disk Drive Unit (APCD-610-150, APCD-610-160
and APCD-610-350) Parts List (Continued)**

Ref #	Part #	Description	Qty
33	S-7008	Nut 5/16"-18 SS	12
34	S-8724	Fender Washer 5/16" x 1-1/2" x 1/16"	2
35	S-8184	Knob Bar 2-1/4" Diameter 5/16" Thread	2
36	APCD-336	Extension Spring	2
37	S-8006	Knob, 1/4"-20 x 1/2" SS Stud	3
38	S-8979	Nutsert 1/4"-20 Yellow Dichromate	3
39	S-8004	Clamp, U-Bolt 5/16"-18 x 2-1/2" (with Saddle)	2
40	S-6732	Screw, MS #10-24 x 1/2" THS SS	4
41	S-7931	Hex Nut #10-24 SS	6
42	APCD-608-150	Gearmotor Chain Disk 1 PH 50 Hz	1
42	APCD-608-160	Gearmotor Chain Disk 1 PH 60 Hz	1
42	APCD-608-350	Gearmotor Chain Disk 3 PH 50/60 Hz	1
43	APCD-601S	Gearbox Assembly for Service, Motovario	1
44	APCD-601	Gearbox, BA72C	1
45	APCD-233M72	Shaft, Motovario BA72C Gearbox	1
46	APCD-234M72W	Bracket Assembly, Gearbox Mount for Motovario, BA72C	1
47	S-10111	Bolt, HHCS M8 - 1-1/4" x 20" SS	9
48	APCD-628	Mounting Plate for Manufacturing Label	1
49	APCD-617-150	Motor, 1.5 HP, 1450 RPM, 1 PH, 50 Hz, 56C, TEFC	1
49	APCD-617-160	Motor, 1.5 HP, 1750 RPM, 1 PH, 60 Hz, 56C, TEFC	1
49	APCD-617-350	Motor, 1.5 HP, 1450/1750 RPM, 3 PH, 50/60 Hz, 56C, TEFC	1
50	S-8033	Flange Bolt 3/8"-16 x 1" SS	4
51	APCD-014	Main Drive Sprocket - Machined	1
52	S-7991	Fender Washer 11/32" I.D. x 2" O.D. SS	1
53	APCD-351	Cord Assembly for 1 PH, 50/60 Hz	1
53	APCD-351-3PH	Cord Assembly for 3 PH, 50/60 Hz	1
54	S-7413	Bolt, HHCS 1/2"-13 x 1" SS	4
55	S-7417	Nylock Nut 1/2"-13 SS	4
56	HT-1414	3/16" Proof Chain - 10'	4
57	APCD-055	Eye Bolt 5/16" x 4" SS Lag	4
58	S-7977	Connecting Link	1
59	APCD-605-150	Chain and Disk Assembly Bag of 150'	1
59	APCD-605-100	Chain and Disk Assembly Bag of 100'	1
59	APCD-605-50	Chain and Disk Assembly Bag of 50'	1
59	APCD-605-20	Chain and Disk Assembly Bag of 20'	1

Fill Hopper Assembly

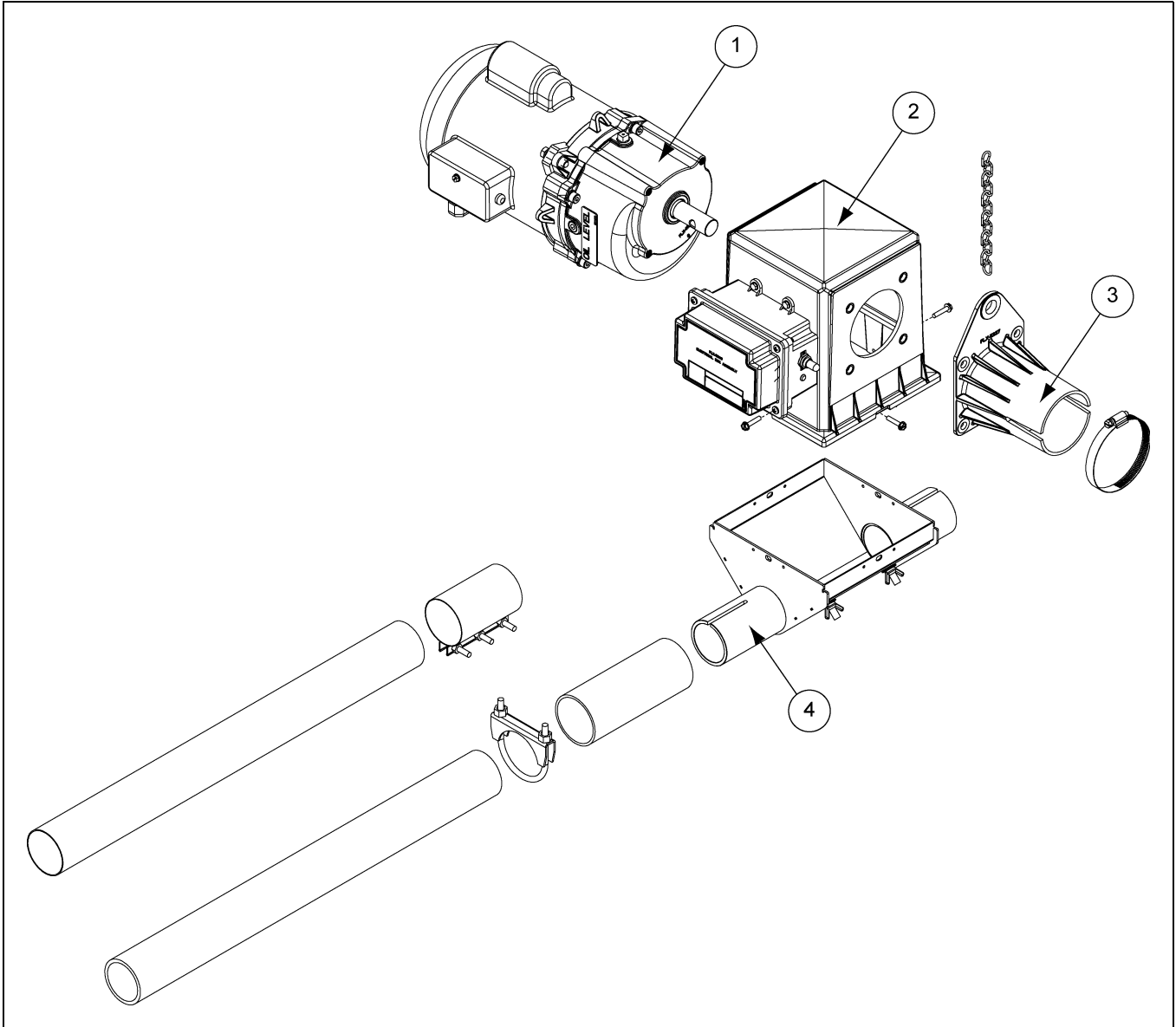

Fill Hopper Assembly Parts List

Ref #	Part #	Description
		DDPU Use Correct HP Rating for Flex-Flo
1	FLX-4403	Gearbox FF, 6.5:1, 250 RPM at 60 Hz, 219 RPM at 50 Hz, without Pinion
2	FLX-5298	Model 220-300-350 Control Unit, 220V
3	FLX-2696	Model 300 Direct Drive Driver and Tube Anchor Package
4	APCD-620	Fill Hopper Assembly

PVC - Clear

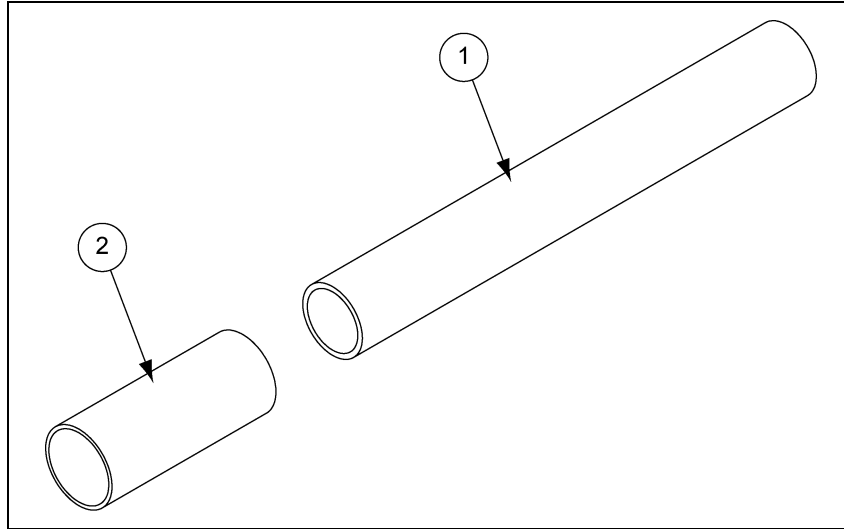

PVC - Clear Parts List

Ref #	Part #	Description
1	APCD-104	Tube, Model 236 Clear PVC, 10' Sections
2	APCD-105	Coupler, Model 236 Clear PVC

PVC - White

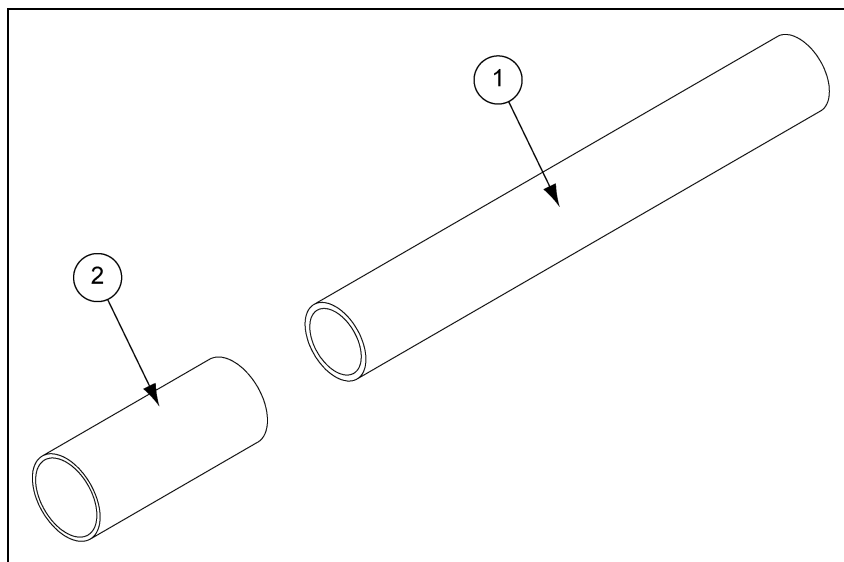

PVC - White Parts List

Ref #	Part #	Description
1	APCD-112	Model 236 White PVC Tube, 10' Sections
2	APCD-113	Model 236 White PVC Coupler

Welded Steel Tubing

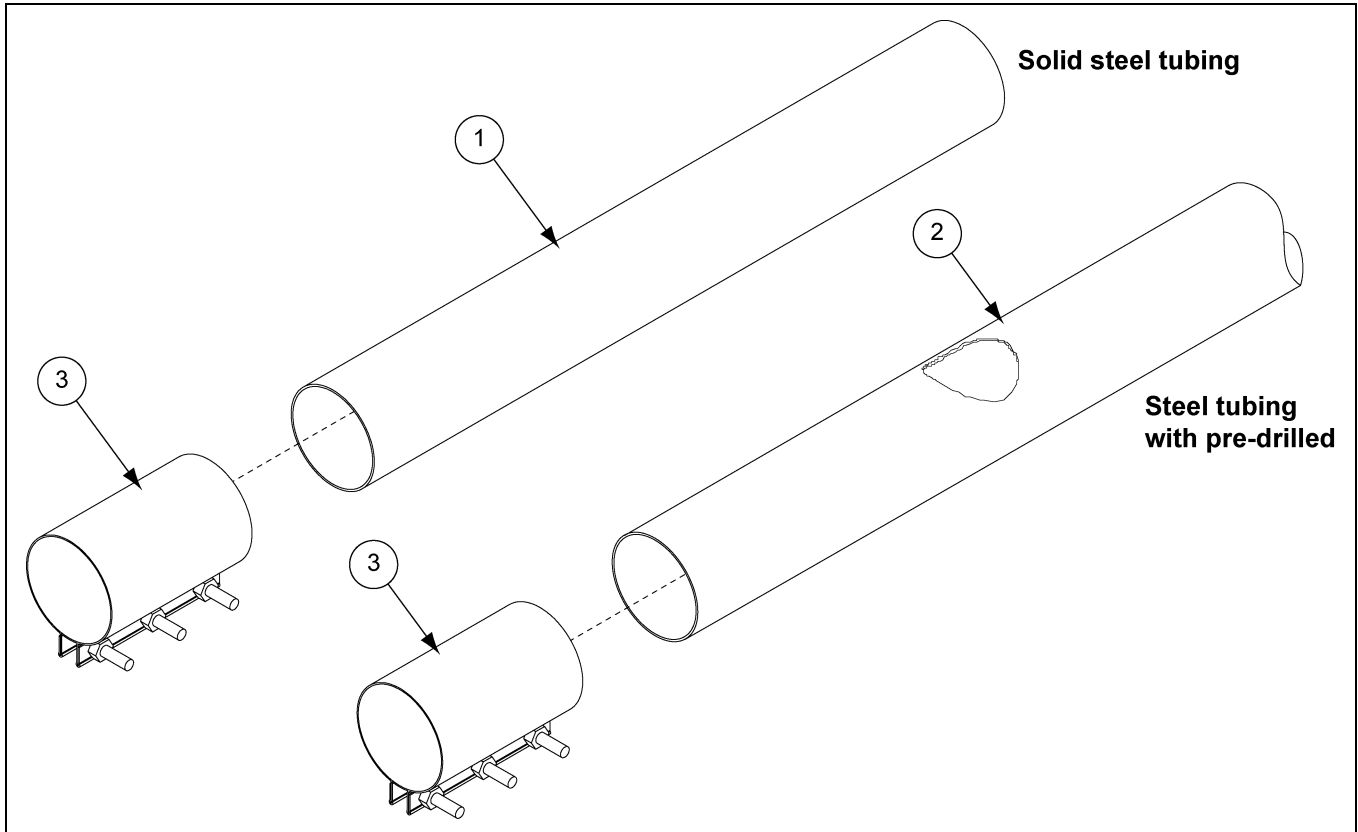

Welded Steel Tubing Parts List

Ref #	Part #	Description
1	APCD-217	Tube, Electric Weld, Round, 2-3/8" O.D., 18 Ga., 10' Long, G90 Galvanized
1	APCD-217-21	Tube, Electric Weld, Round, 2-3/8" O.D., 18 Ga., 21' Long, G90 Galvanized
2	APCD-748-18	CD Steel Tubing, 13 Holes, 18" Spacing, Single
2	APCD-748-18B	CD Steel Tubing, 13 Holes, 18" Spacing, BDL of 10
2	APCD-748-19	CD Steel Tubing, 13 Holes, 19" Spacing, Single
2	APCD-748-19B	CD Steel Tubing, 13 Holes, 19" Spacing, BDL of 10
2	APCD-748-20	CD Steel Tubing, 12 Holes, 20" Spacing, Single
2	APCD-748-20B	CD Steel Tubing, 12 Holes, 20" Spacing, BDL of 10
2	APCD-748-22	CD Steel Tubing, 11 Holes, 22" Spacing, Single
2	APCD-748-22B	CD Steel Tubing, 11 Holes, 22" Spacing, BDL of 10
2	APCD-748-23	CD Steel Tubing, 10 Holes, 23" Spacing, Single
2	APCD-748-23B	CD Steel Tubing, 10 Holes, 23" Spacing, BDL of 10
2	APCD-748-24	CD Steel Tubing, 10 Holes, 24" Spacing, Single
2	APCD-748-24B	CD Steel Tubing, 10 Holes, 24" Spacing, BDL of 10
3	APCD-408	Coupler, 2-3/8" Pipe Sleeve with Hardware

Drop Kits

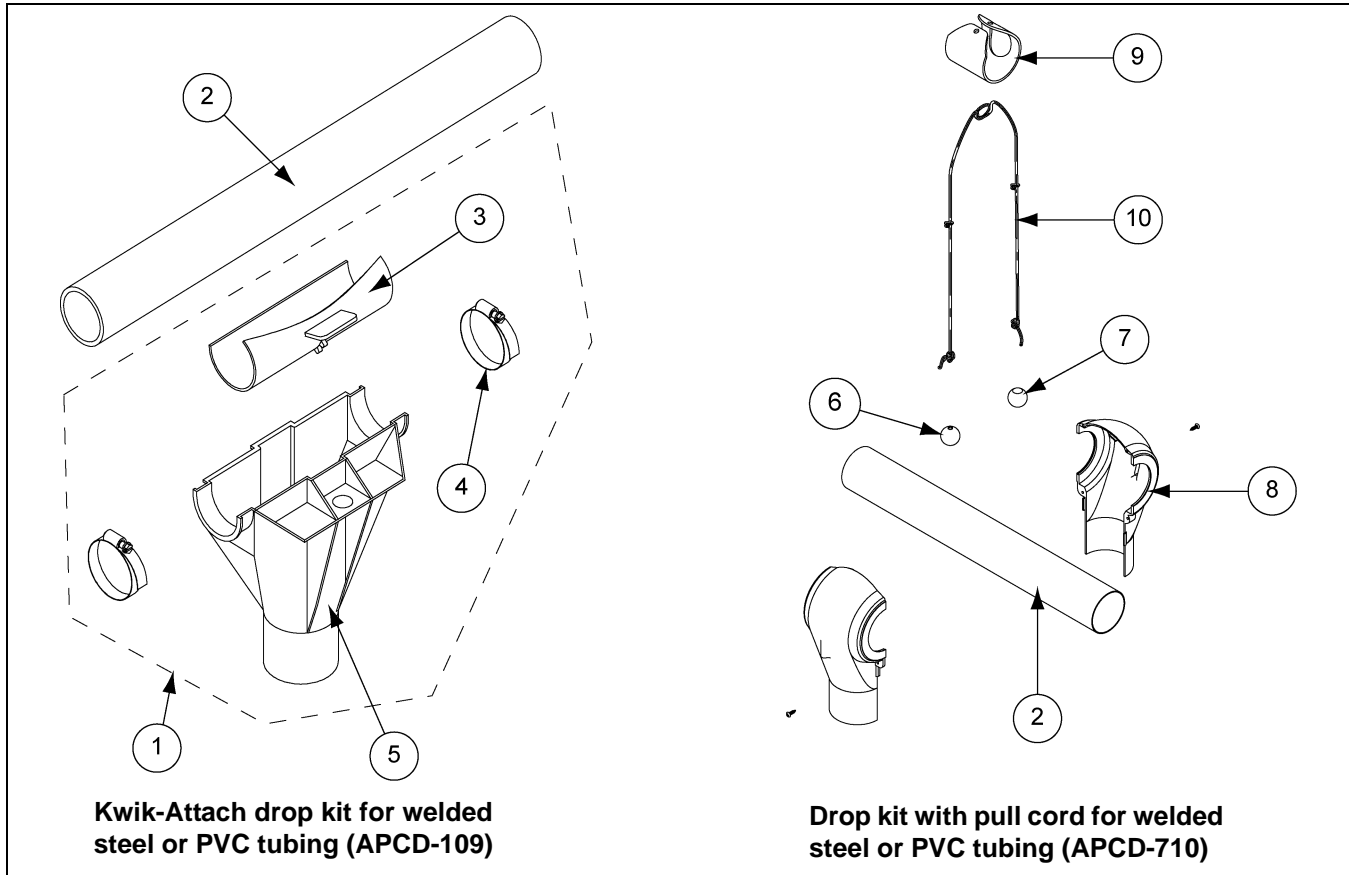

Drop Kits Parts List

Ref #	Part #	Description	Qty
1	APCD-109	Drop Kit, Kwik-Attach (Single)	
1	APCD-110	Drop Kit, Kwik-Attach (Box of 10)	
1	APCD-710	Pull Cord Style Drop Kit (Single)	
1	APCD-710-10	Pull Cord Style Drop Kit (Box of 10)	
2	APCD-104	Tube, Model 236 Clear PVC, 10' Sections	
2	APCD-112	Model 236 White PVC Tube, 10' Sections	
2	APCD-217	Tube, Electric Weld, Round, 2-3/8" O.D., 18 Ga, 10' Long, G90 Galv.	
2	APCD-217-21	Tube, Electric Weld, Round, 2-3/8" O.D., 18 Ga, 21' Long, G90 Galv.	
3	APCD-058	Slide, Kwik-Attach Drop Kit	1
4	AP-0583	Clamp, Hose, Stainless Steel 1-13/16" to 2-3/4"	2
5	APCD-059	Housing, Kwik-Attach Drop Kit	1
6	FLX-2441	Indicator Ball (Green)	1
7	FLX-2442	Indicator Ball (Red)	1
8	FLX-237D	Drop Half for APCD-710	1
9	FLX-2437	Shut Off Slide	1
10	CW-2008-1M	Cord, 1/8" #4 White Solid Braided	1

15. Parts List

Chain Disk Control Unit

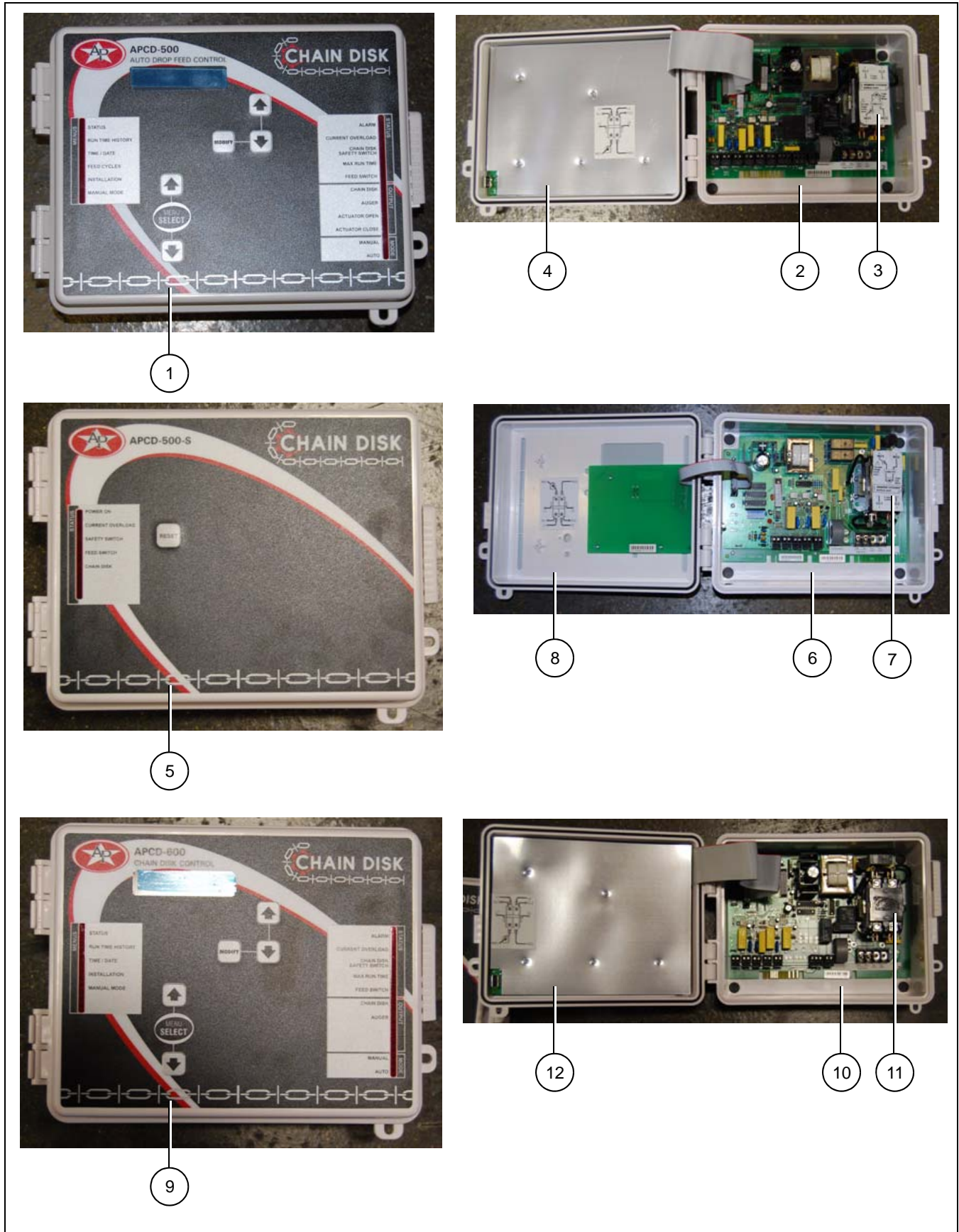

Chain Disk Control Unit Parts List

Ref #	Part #	Description
1	APCD-500	Chain Disk Auto Drop Feed Master Control
2	APCD-500B	Bottom Board for APCD-500
3	APCD-393	Relay for APCD-500
4	APCD-500T	Top Board for APCD-500
5	APCD-500-S	Chain Disk Slave Control
6	APCD-500B-S	Bottom Board for APCD-500-S
7	APCD-393	Relay for APCD-500-S
8	APCD-500T-S	Top Board for APCD-500-S
9	APCD-600	Chain Disk Continuous Feed Control
10	APCD-600B	Bottom Board for APCD-600
11	APCD-393	Relay for APCD-600
12	APCD-600T	Top Board for APCD-600

16. Troubleshooting

Problem	Possible Cause	Corrective Action
Chain Disk motor will not run.	Chain Disk motor will not run.	Check circuits, fuses and ON-OFF switches on equipment.
	Limit switch activated in drive unit.	Refer to limit switch on Page 37 .
	Motor thermal overload switch activated.	Refer to motor overload reset button in Figure 14A on Page 50 . Check current sensor setting.
Motor overloads after running briefly.	Low voltage (motor runs slow and overheats).	Check line voltage at motor; use adequate wire size in circuits.
	Foreign object caught in chain.	Check system for any foreign objects and remove them.
	Chain Disk System to full with feed.	Check Flex-Flo fill system rate; check feed sensing switch; check current sensor setting.
	Wet feed being conveyed or allowed to stand in system.	Clean the system; avoid conveying wet feed or empty line after each feeding.
	Defective motor.	Replace motor.
Limit switch activated.	Chain in system not tight enough.	Take out a section of chain referring to Page 47 ; pull reset button.
	Chain has broken somewhere in system.	Find where chain has broken and fix using special connector link; reset limit switch and then pull control unit reset button.
	Foreign object in system.	Check system for any foreign objects and remove them; reset limit switch and then push the control unit reset button.
	Chain Disk System to full with feed.	Check Flex-Flo fill system rate; check feed sensing switch; reset limit switch and then push control unit reset button.
Chain Disk motor does not shut OFF when full.	Proximity switch sensitivity improperly adjusted. (Not sensitive enough.)	Refer to Page 47 for proper proximity switch adjustment.
Chain Disk motor always shut OFF immediately after prox by-pass time.	Proximity switch sensitivity improperly adjusted. (Too sensitive.)	Refer to Page 47 for proper proximity switch adjustment.

Limited Warranty - Protein Products

The GSI Group, LLC. ("GSI") warrants products which it manufactures, to be free of defects in materials and workmanship under normal usage and conditions for a period of 12 months from the date of purchase (or, if shipped by vessel, 14 months from the date of arrival at the port of discharge). If, in GSI's sole judgment, a product is found to have a defect in materials and/or workmanship, GSI will, at its own option and expense, repair or replace the product or refund the purchase price. This Limited Warranty is subject to extension and other terms as set forth below.

Warranty Enhancements:

The warranty period for the following products is enhanced as shown below and is in lieu of (and not in addition to) the above stated warranty period.

	Product	Warranty Period	
AP® Fans	Performer Series Direct Drive Fan Motor	3 Years	* Warranty prorated from material list price: 0 to 3 years - no material cost to end user 3 to 5 years - end user pays 25% 5 to 7 years - end user pays 50% 7 to 10 years - end user pays 75%
AP® and Cumberland®	Flex-Flo/Pan Feeding System Motors	2 Years	
Electronic Controls	All Protein controls manufactured by GSI	24 Months from date code on part	
Cumberland® Feeding and Watering Systems	Feeder System Pan Assemblies	5 Years, Prorated **	** Warranty prorated from material list price: 0 to 3 years - no material cost to end user 3 to 5 years - end user pays 75%
	Feed Tubes (1.75" and 2.00")	10 Years, Prorated *	
	Centerless Augers	10 Years, Prorated *	
	Watering Nipples	10 Years, Prorated *	

Conditions and Limitations:

THERE ARE NO WARRANTIES THAT EXTEND BEYOND THE LIMITED WARRANTY DESCRIPTION SET FORTH HEREIN; SPECIFICALLY, GSI DISCLAIMS ANY AND ALL OTHER WARRANTIES OF ANY KIND, EXPRESS OR IMPLIED, INCLUDING, WITHOUT LIMITATION, WARRANTIES OF MERCHANTABILITY OR FITNESS FOR A PARTICULAR PURPOSE OR USE IN CONNECTION WITH: (I) ANY PRODUCT MANUFACTURED OR SOLD BY GSI, OR (II) ANY ADVICE, INSTRUCTION, RECOMMENDATION OR SUGGESTION PROVIDED BY AN AGENT, REPRESENTATIVE OR EMPLOYEE OF GSI REGARDING OR RELATED TO THE CONFIGURATION, INSTALLATION, LAYOUT, SUITABILITY FOR A PARTICULAR PURPOSE, OR DESIGN OF SUCH PRODUCTS.

The sole and exclusive remedy for any claimant is set forth in this Limited Warranty and shall not exceed the amount paid for the product purchased. This Warranty only covers the value of the warranted parts and equipment, and does not cover labor charges for removing or installing defective parts, shipping charges with respect to such parts, any applicable sales or other taxes, or any other charges or expenses not specified in this Warranty. GSI shall not be liable for any other direct, indirect, incidental or consequential damages, including, without limitation, loss of anticipated profits or benefits. Expenses incurred by or on behalf of a claimant without prior written authorization from the GSI warranty department shall not be reimbursed. This warranty is not transferable and applies only to the original end user. GSI shall have no obligation or responsibility for any representations or warranties made by or on behalf of any dealer, agent or distributor. Prior to installation, the end user bears all responsibility to comply with federal, state and local codes which apply to the location and installation of the products.

This Limited Warranty extends solely to products sold by GSI and does not cover any parts, components or materials used in conjunction with the product, that are not sold by GSI. GSI assumes no responsibility for claims resulting from construction defects, unauthorized modifications, corrosion or other cosmetic issues caused by storage, application or environmental conditions. Modifications to products not specifically delineated in the manual accompanying the product at initial sale will void all warranties. This Limited Warranty shall not extend to products or parts which have been damaged by negligent use, misuse, alteration, accident or which have been improperly/inadequately maintained.

Service Parts:

GSI warrants, subject to all other conditions described in this Warranty, Service Parts which it manufactures for a period of 12 months from the date of purchase, unless specified in Enhancements above. Parts not manufactured by GSI will carry the Manufacturer's Warranty.

(Protein Limited Warranty_REV01_06 November 2018)

This equipment shall be installed in accordance with the current installation codes and applicable regulations, which should be carefully followed in all cases. Authorities having jurisdiction should be consulted before installations are made.



**1004 E. Illinois St.
Assumption, IL 62510-0020
Phone: 1-217-226-4421
Fax: 1-217-226-4420
www.automatedproduction.com / www.cumberlandpoultry.com**

