

DATE:

CUSTOMER PRINT:

CUSTOMER SIGN:

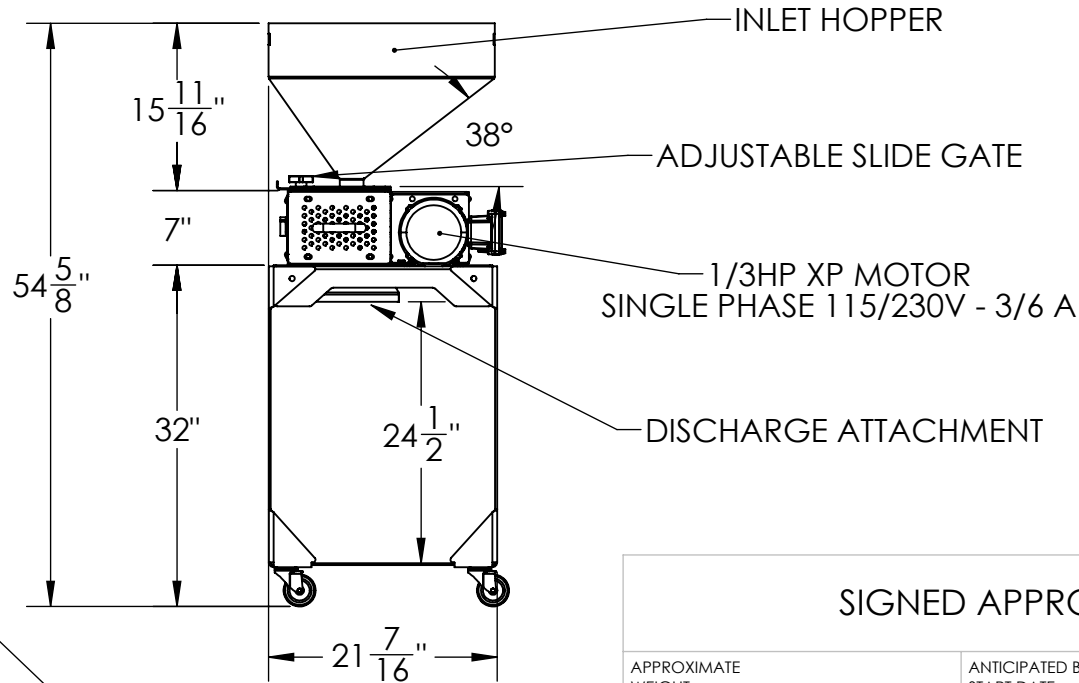
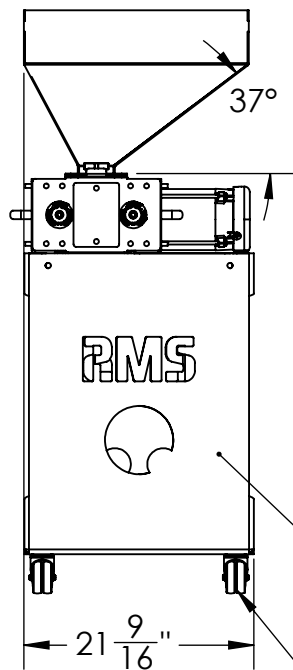
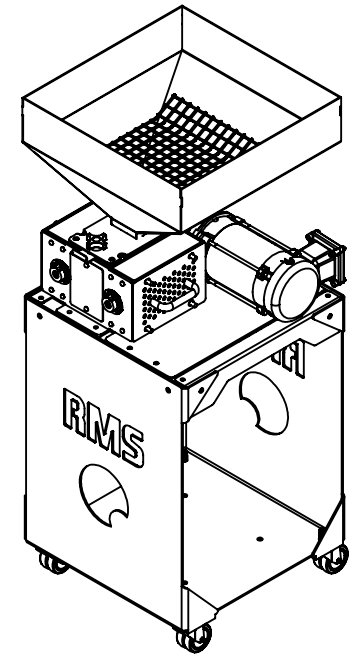
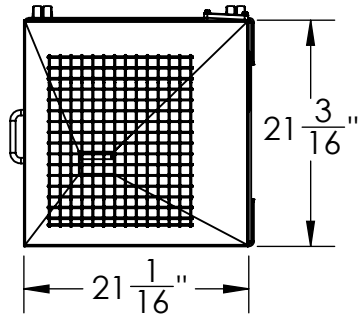

32" STAND  
 CASTERS SHOWN ARE AN OPTIONAL UPGRADE

<b>SIGNED APPROVAL</b>		USE TOLERANCE BLOCK UNLESS OTHERWISE SPECIFIED: .XX ± .02 .XXX ± .010 .XXXX ± .0005 FRACTIONS= ±1/16 ANGLES= ±1°	
APPROXIMATE WEIGHT:	ANTICIPATED BUILT START DATE:	<b>Micro Mill</b>	
VENDOR:	DESCRIPTION:		
VENDOR #:			
UNLESS OTHERWISE SPECIFIED: DIMENSIONS ARE IN INCHES.			
DRAWING SIZE: <b>A</b>	REVISION: <b>A</b>		
ANTICIPATED SHIP DATE:	DWG NO. <b>3X3SP</b>	DRAWN BY: <b>CJV</b>	DATE: <b>7/27/20</b>
WEIGHT: 105.800210.55786073	SCALE: 1:18	SHEET 3 OF 4	