

DATE:

CUSTOMER PRINT:

CUSTOMER SIGN:

NOTE: MAIN GRINDING MOTORS ARE NOT VFD COMPATIBLE.

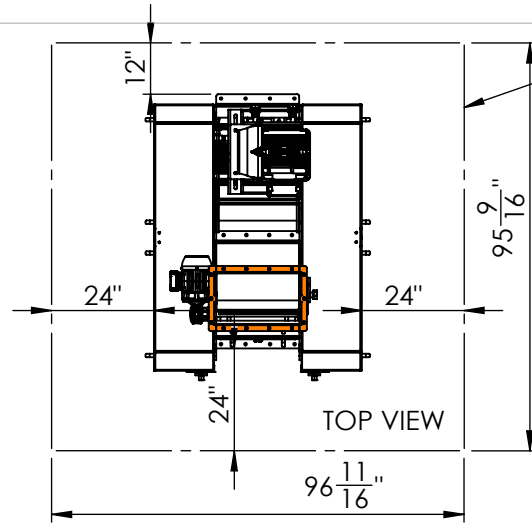

MINIMUM SPACE REQUIRED FOR PROPER MAINTENANCE

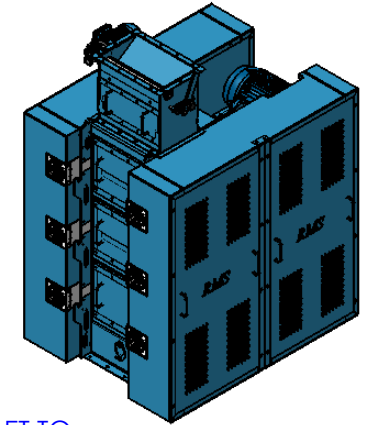

QTY. 1 - 1/2HP TEFC OR XP 1800 RPM 3 PHASE AGITATOR MOTOR

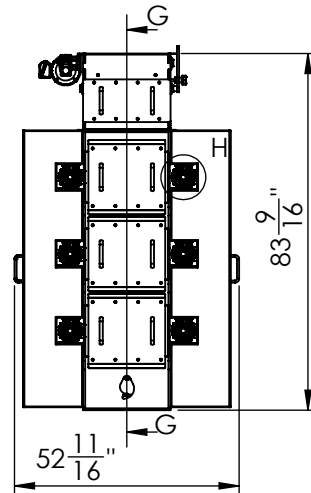
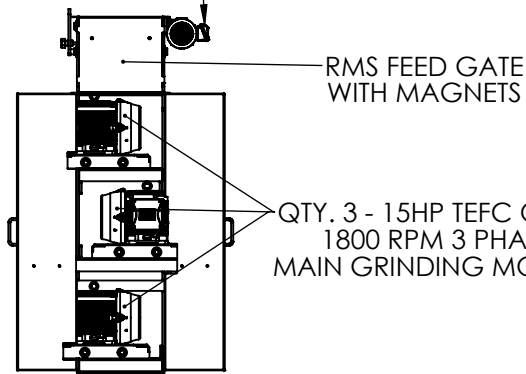

2 1/8" CENTER OF INLET TO CENTER OF DISCHARGE

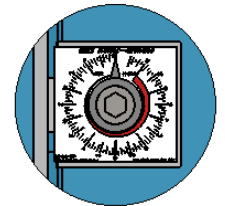
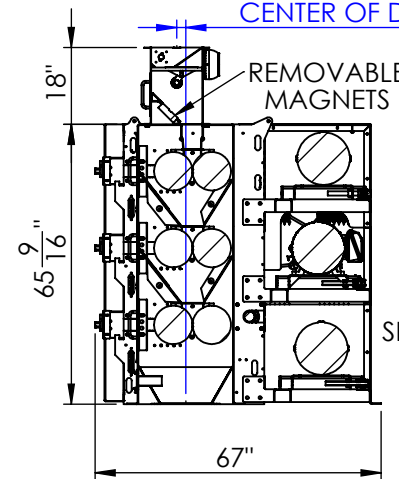

DETAIL H SCALE 1 : 10

CENTERED, 12" W X 12" L STANDARD DISCHARGE

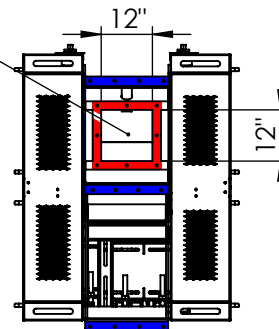

BOTTOM VIEW

SIGNED APPROVAL

USE TOLERANCE BLOCK UNLESS OTHERWISE SPECIFIED:
 .XX ± .02
 .XXX ± .010
 .XXXX ± .0005
 FRACTIONS= ±1/16
 ANGLES= ±1°

APPROXIMATE WEIGHT: 5,800 LBS.

ANTICIPATED BUILT START DATE:

VENDOR: VENDOR #:

DESCRIPTION:

UNLESS OTHERWISE SPECIFIED: DIMENSIONS ARE IN INCHES.

9X18 TRIPLE PAIR ROLLER GRINDER WITH MAGNET GATE

DRAWING SIZE: A REVISION:

ANTICIPATED SHIP DATE:

DWG NO.

DRAWN BY:

DATE:

9X18TP

WEIGHT:

SCALE:1:45

SHEET 4 OF 7