

DATE:

CUSTOMER PRINT:

CUSTOMER SIGN:

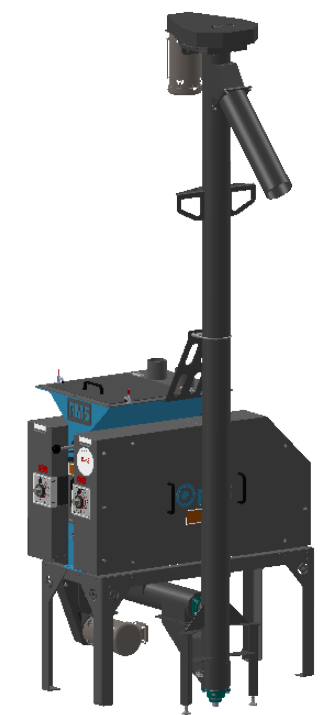
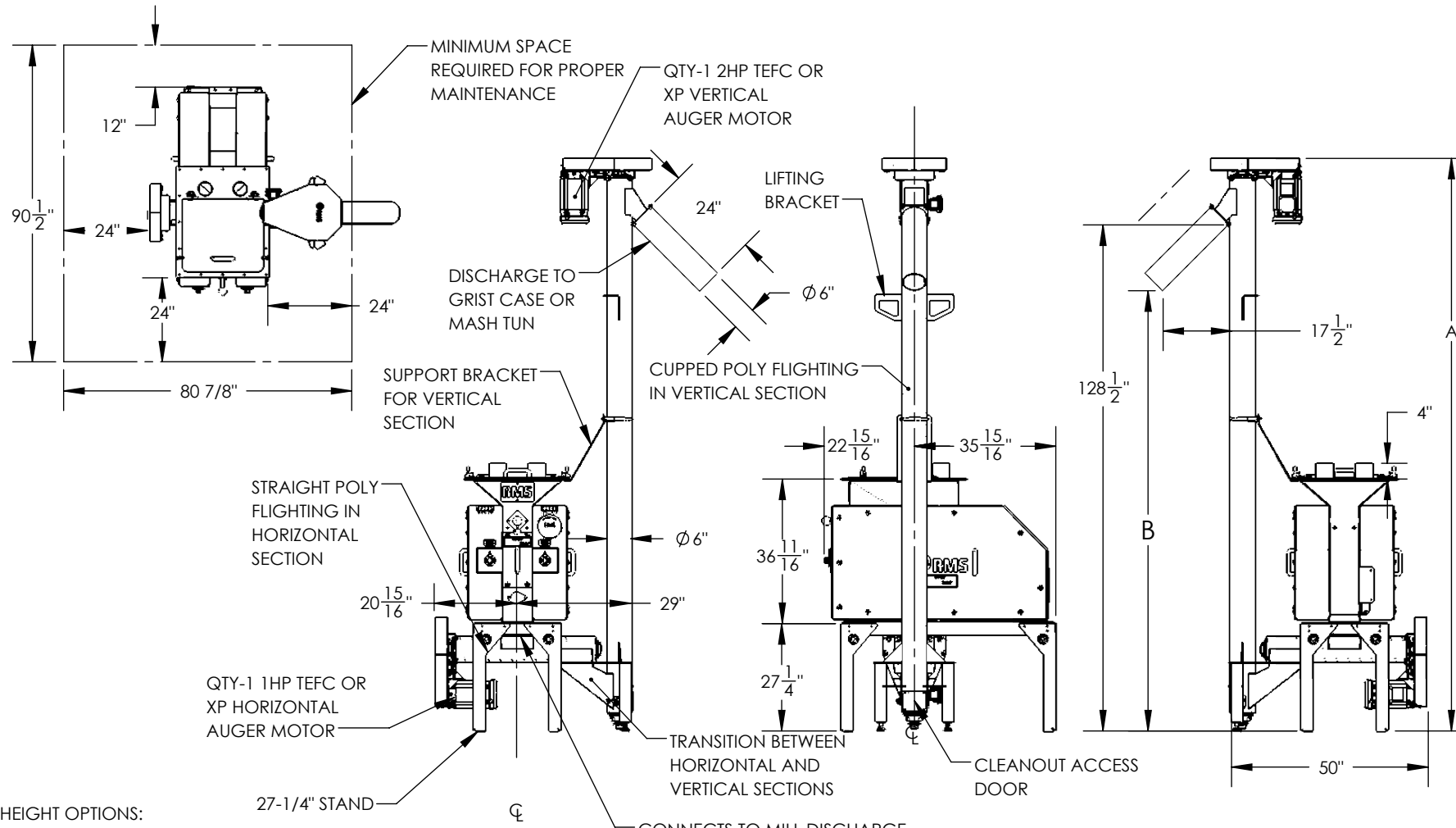

HEIGHT OPTIONS:

OPTION 1:
 OVERALL HEIGHT (A): 145"
 DISCHARGE HEIGHT (B): 111"

OPTION 2:
 OVERALL HEIGHT (A): _____
 DISCHARGE HEIGHT (B): _____

CUSTOM HEIGHT:
 OVERALL HEIGHT (A): _____
 DISCHARGE HEIGHT (B): _____

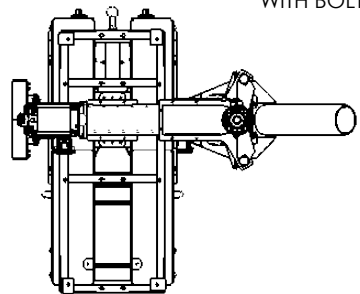

SIGNED APPROVAL

USE TOLERANCE BLOCK
 UNLESS OTHERWISE SPECIFIED:
 .XX ± .02
 .XXX ± .010
 .XXXX ± .0005
 FRACTIONS= ±1/16
 ANGLES= ±1°

APPROXIMATE WEIGHT:
 VENDOR:
 VENDOR #:
 UNLESS OTHERWISE SPECIFIED:
 DIMENSIONS ARE IN INCHES.
 DRAWING SIZE: **A** REVISION:
 ANTICIPATED SHIP DATE:

ANTICIPATED BUILT START DATE:
 DESCRIPTION:
**9X6 SINGLE PAIR
 VERTICAL AUGER BREW SYSTEM**
 DWG NO. **9X6SP 2018** DRAWN BY: **KSD** DATE: **6/22/17**